



*Great sound  
from Barcelona  
since 1972*

[www.amateaudio.com](http://www.amateaudio.com)

## **User's manual**

# **X212AFD**

# **XCELLENCE**

July 2021

Amate Audio S.L.

EXPORT & CUSTOMER SERVICE  
Perpinyà, 25 · Polígon Industrial Nord  
08226 Terrassa · Barcelona – SPAIN  
T. +34 93 735 65 65  
[export@amateaudio.com](mailto:export@amateaudio.com)

R&D, FACTORY AND MANAGEMENT  
Violinista Vellsolà, 18  
08222 Terrassa · Barcelona – SPAIN  
T. +34 93 736 23 90  
[info@amateaudio.com](mailto:info@amateaudio.com)

## Safety Instructions

1. All safety instructions must be read before using this device.
2. The exclamation mark in the triangle indicates internal components which if replaced can affect safety.
3. The lightning symbol within the triangle indicates the presence of dangerous uninsulated voltages.
4. This device must not be exposed to rain or humidity. It must not be used for example near swimming pools, fountains or any other place where it might be affected by liquids.
5. Only clean the device with a dry cloth.
6. Do not situate the equipment where its ventilation system might be interfered with.
7. Do not install the device near heat sources such as radiators, heaters or other heat-emitting elements.
8. The equipment must be repaired by qualified technical service personnel when:
  - A. The mains supply cable is damaged, or
  - B. Any object or liquid has damaged the device; or
  - C. The equipment does not function normally or correctly; or
  - D. The equipment has been exposed to the rain; or
  - E. The chassis is damaged
9. Disconnect the device in the case of electric storms or during long periods of disuse.
10. Never hang the equipment by its handle.
11. Only use manufacturer recommended accessories.

## 1 INTRODUCTION

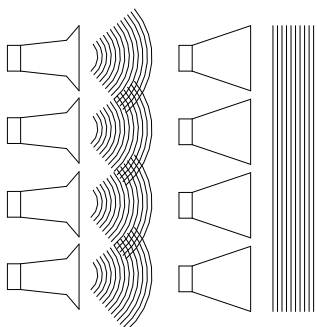
### 1.1 General product information

Amate Audio thanks you for the trust placed in our Xcellence loudspeaker systems. The Xcellence series combines the convenience of a self-powered system and the flexibility of the DSP (digital system processing) for cabinet control. More than 45 years' experience in amplifier and acoustic cabinet design using the highest technology and components come together to give you a product ideal for a multitude of applications, especially those which require high levels of sound pressure and a control of vertical coverage. Stadiums, theatres or big events will become the perfect places for their use. We suggest you read the following information with attention, assured that it will be of maximum use in helping you to achieve the best results and optimum performance.

### 1.2 What is a line array?

The trend in sound reinforcement has been to increase both the sound pressure level (SPL) and the size of the audience to be covered. This leads to an increase in the number of cabinets and, as a result of this, an increase in the total size and weight.

A line array is a group of independent sound sources which are vertically stacked in order to transform the spherical wave fronts generated by individual sources into a single flat wave front.



**Fig.1.** Wave field interference for different wave fronts.

To carry out effectively arraying individual sound sources the system must follow the acoustic coupling conditions based on the wavelength, the shape of each source, the surface area of each transducer and the relative source separation.

An assembly of individual sound sources arrayed with regular separation between the sources on a plane or curved continuous surface is equivalent to a single sound source having the same dimensions as the total assembly if the following conditions are fulfilled:

- The step of source separation, defined as the distance between the acoustic centres of the individual sources, is smaller than half the wavelength over the bandwidth of operation.

$$d \leq \lambda/2$$

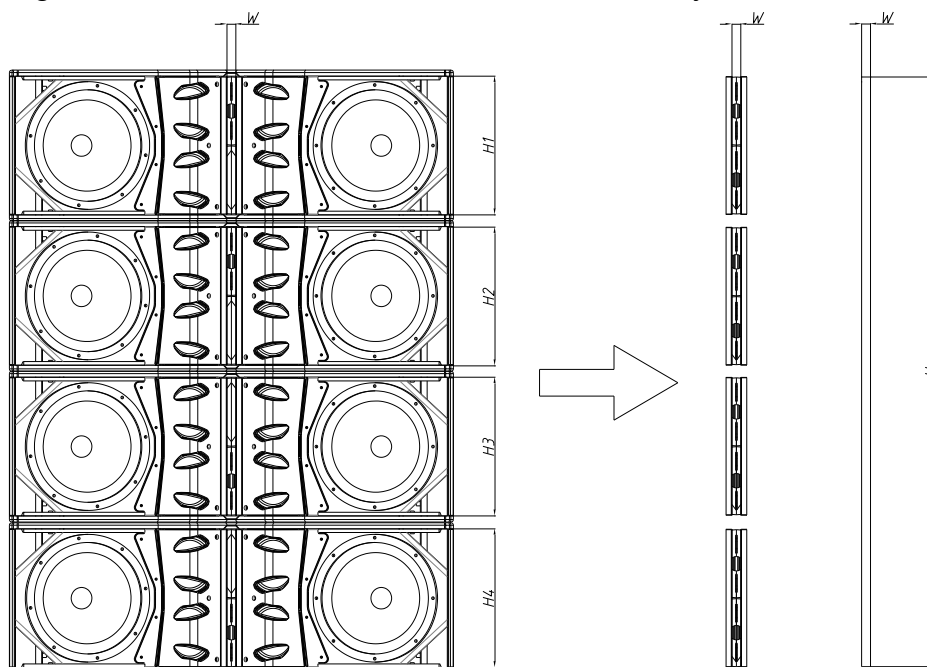
It is not difficult to fulfil this first condition for the low and mid frequencies. For example, two 7" loudspeakers that are separated by 17 cm will reproduce a cylindrical wave up to 1015 Hz.

This condition is difficult to be fulfilled for the high frequencies, as their wavelengths are too small to make the adjacent acoustic centres any smaller than  $\lambda/2$ . Here comes the second "arrayability" criterion.

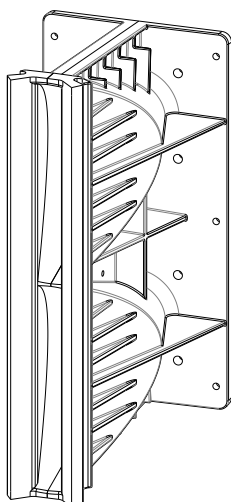
- The wave fronts generated by the individual sources are planar and the combined surface area of the sources fills at least 80% of the total target surface area:

$$H_1 \cdot W + H_2 \cdot W + \dots + H_n \cdot W \geq 0.8 \cdot H \cdot W$$

This is achieved by using waveguides, which are coupled to the compression drivers output. We achieve flat wave fronts with a constant phase. By vertically assembling these waveguides we fulfil the second criterion of line array construction.



**Fig.2.** Second criterion of "arrayability"



- The deviation from a flat wave front must be less than  $\lambda/4$  at the highest operating frequency (this corresponds to less than 5 mm curvature at 16 kHz).

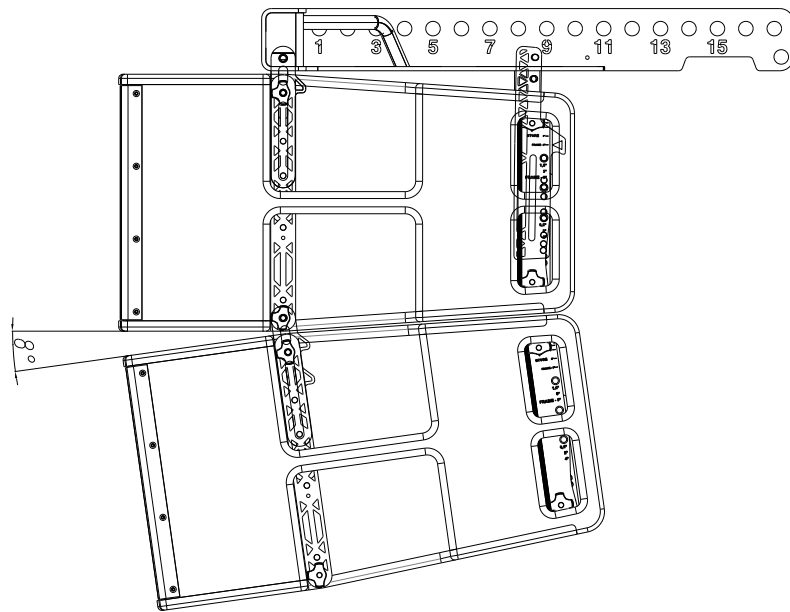
This third condition can be explained through our property waveguide. Thanks to some complex mathematical calculations we have obtained a component which is able to adapt the circular section of the compression driver to a rectangular section, getting on-phase waves at the end of the guide. This flat wave front is ideal for vertical configurations.

**Fig.3.** High frequency waveguide

Sound engineers use line arrays to obtain narrow directivities on the vertical plane. For configurations with many cabinets (big height) and at high frequencies it is not unusual to achieve narrow angles- in some cases they may be grade fractions. This can be useful in venues where both a high sound pressure level and long throw are required; nevertheless, this means less coverage of the audience area.

It is sometimes useful to achieve an asymmetrical coverage pattern on the vertical plane, which can be obtained by aiming some of the cabinets through their hinging points. We are now ready to define the last two criteria of "arrayability".

- For curved arrays, the tilt angles should vary in inverse proportion to the listener distance (this is geometrically equivalent to shaping variable curvature arrays to provide equal spacing of individual element impact zones).
- There are limits given the vertical size of each cabinet and their relative tilt angles. In our case the maximum tilt angle (between cabinets) is  $8^\circ$ .



**Fig.4.** Tilt angle between cabinets (8° maximum)

### 1.3 Fresnel Region (Near Field) and Fraunhofer Region (Far Field)

As our system is able to fulfil the previous conditions it will produce cylindrical waves to a maximum frequency. The wave will be flat up to a certain distance where it will start to become spherical (depending on the frequency and the size of the array).

The limit distance between the zone of cylindrical waves (Fresnel) and spherical waves (Fraunhofer) can be calculated through the following formula:

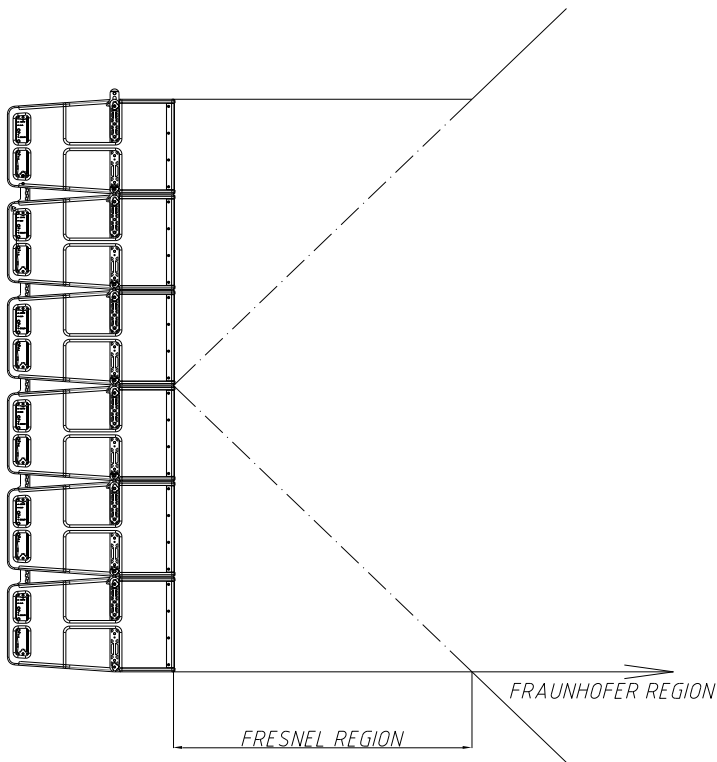
$$d_c = \frac{3}{2} H^2 f \sqrt{1 - \left( \frac{1}{3Hf} \right)^2}$$

where,

$d_c$  = limit distance between near field and far field (in metres)

$H$  = height of the array (in metres)

f= frequency (in kHz)



In the near field region (Fresnel), the wave front is cylindrical and waves only expand on the horizontal plane (100°). The height of the wave front is, in this case, the total height of the array.

In the far field region (Fraunhofer), the wave front is spherical and expands both on the horizontal and vertical planes. The horizontal coverage is 100° and the vertical coverage is defined by the frequency and the height of the array.

**Fig.5.** Limits of Fresnel-Fraunhofer Regions

We can create a chart with some of the basic configurations and their performance regarding wave propagation.

	6xX212AF	9xX212AF	12xX212AF
500Hz	3.6 m	8.5 m	15 m
1000Hz	7.8 m	17 m	30 m
2000Hz	16 m	34 m	60 m
4000Hz	32 m	68 m	120 m
8000Hz	64 m	136 m	240 m
16000Hz	127 m	272 m	480 m

**Fig.6.** d<sub>c</sub> Calculation

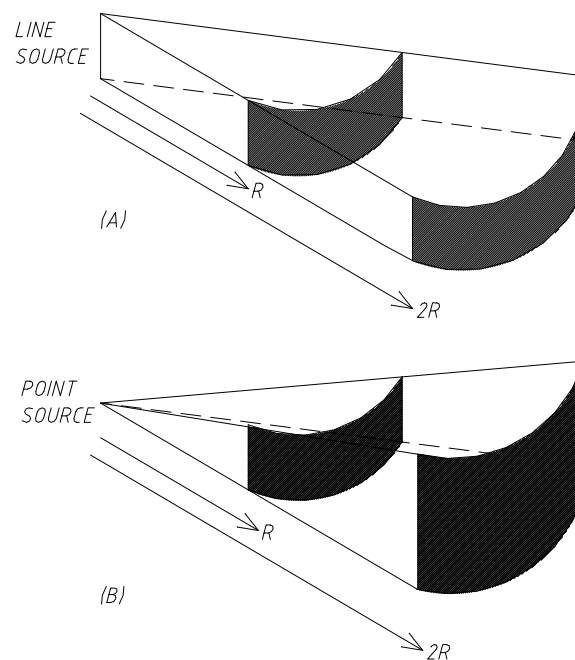
A 6-cabinet array has a near field extending to 16 metres at 2kHz. Beyond this distance the wave front will be spherical.

In the first zone (Fresnel), sound pressure loss is only 3 dB per doubling of distance, whereas in the second zone (Fraunhofer) the loss is 6 dB. In long throw and high SPL configurations it is very important to produce cylindrical waves.

**Fig.7.** Cylindrical wave (A) vs Spherical wave (B)

(A): -3 dB / doubling of distance

(B): -6 dB / doubling of distance



#### 1.4 Features and presentation

##### X212AFD

- Self-powered three-way acoustic system
- XLR electronically balanced input & XLR parallel link
- AC PowerCon input & link
- EtherCon RJ45 input & link
- 1 Gbps Ethernet connectivity with Dante™ audio networking
- 2000W class D amplifier for bass range
- 1000W class D amplifier for mid-range
- 1000W class D amplifier for high range
- 24-bit AD/DA converters with 112 dB dynamic range, 48 kHz sampling rate
- DSP Controls (presets, parametric EQs, delay, mute, volume and limiter)
- Amplifier self-diagnostics: input level, temperature, limiter active
- Overvoltage protection (>250V-400V)
- 2 x 12" neodymium woofers with 3" voice coil
- 4 x 6" neodymium woofers with 1.5" voice coil coupled to 2 x mid phase plugs
- 2 x 3" titanium diaphragm neodymium drivers coupled to 1 x HF waveguide
- 100 x 8° dispersion

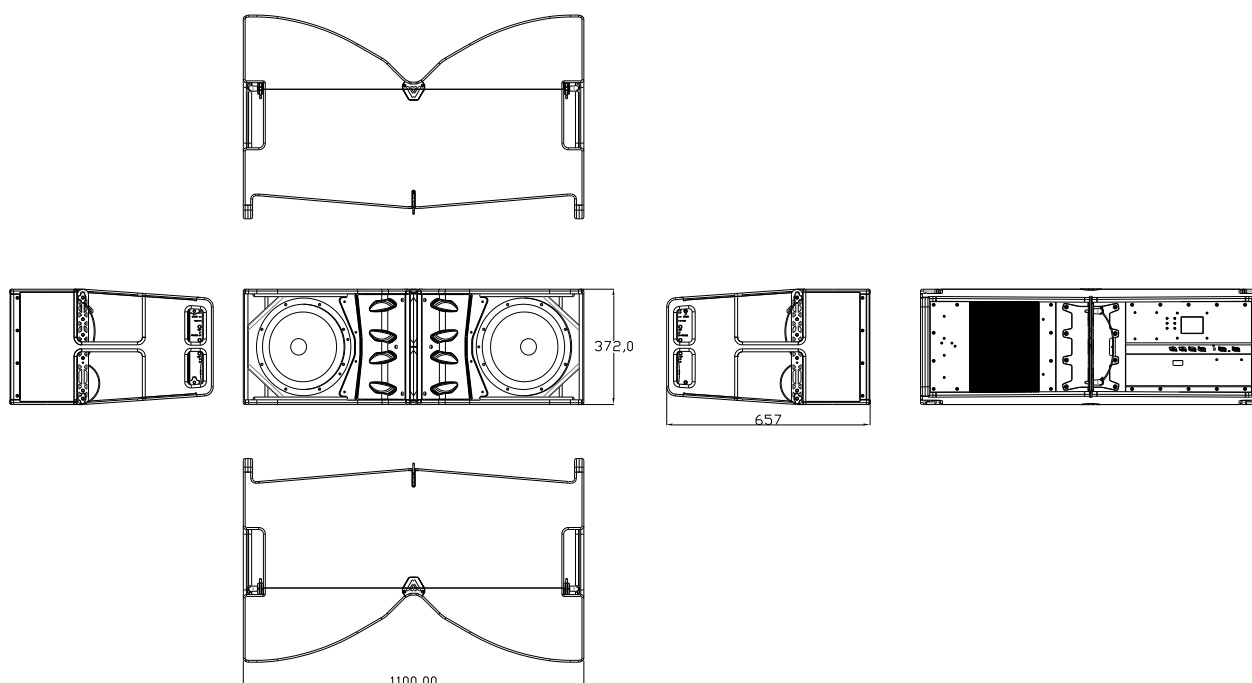


## 2 X212AFD FEATURES

The X212AFD cabinet is ideal for a multitude of applications. It includes 2000W amplification for the low range woofers, 1000W for the mid-range woofers, 1000W for the high range compression drivers and digital signal control by DSP. The manufacturer presets make it easy, flexible and user-friendly. The result is a clean, high quality sound at full power in larger sites.

### 2.1 Technical description

The X212AFD cabinet comes with DSP control, full range sound delivery thanks to its direct radiation transducers and acoustic bass reflex cabinet. As a full range system, its response is 42Hz-18 kHz (-10 dB). It has 4000W continuous amplification (2000W + 1000W + 1000W), thermal protection, output short circuit protection, independent peak and RMS power limiters for each channel, and protection against overvoltage. The DSP includes several presets which can be selected either accessing the cabinet's rear control screen or via the computer with Ethernet connection.



**Fig.8.** X212AFD external dimensions

The X212AFD cabinet is connected using the XLR balanced connector or via Dante™ audio networking, using the RJ45 connectors. Mains supply is through PowerCon. It is built in birch plywood, which has a high resistance to vibrations and humidity with black Polyurea paint coating. The front face is protected by two 1.5 mm thick steel grilles with acoustically transparent grey cloth. It includes two in-built lateral handles for an easy and comfortable transport.

### 3 PRESETS

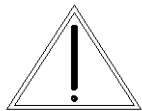
The X212AFD includes several manufacturer presets for different types of application. The DSP system can also store up to 25 other presets, depending on user requirements

#### 3.1 Standalone line source

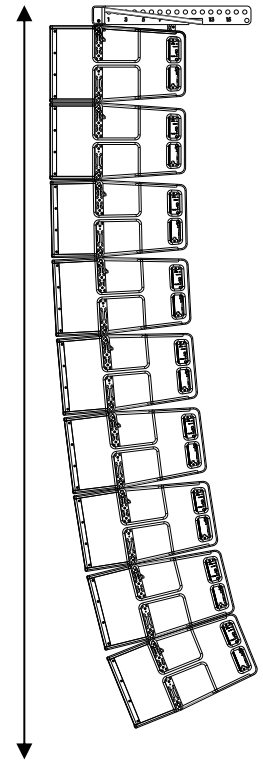
Deployed as a line source system, the system operates over the nominal bandwidth of the X212AFD enclosure (42 Hz – 18 kHz, -10dB).

Model: X212AFD  
Preset:[HPF60 FLAT]

[HPF60 FLAT]



The minimum number of cabinets to be used as a standalone line source system is 6 cabinets. We do not recommended to use less than 6 cabinets per side. The optimum number of cabinets per side would be from 8-9 cabinets to up.



#### 3.2 Standalone line source including NearField and Longthrow cabinets

Deployed as a line source system of more than 9 cabinets, you may need to use some cabinets as Longthrow cabinets (the upper ones) and some cabinets as Nearfield cabinets (the lower ones). The system operates over the nominal bandwidth of the X212AFD enclosure (42 Hz – 18 kHz, -10dB).

Model: X212AFD  
Preset: [HPF60 LONGTHROW]

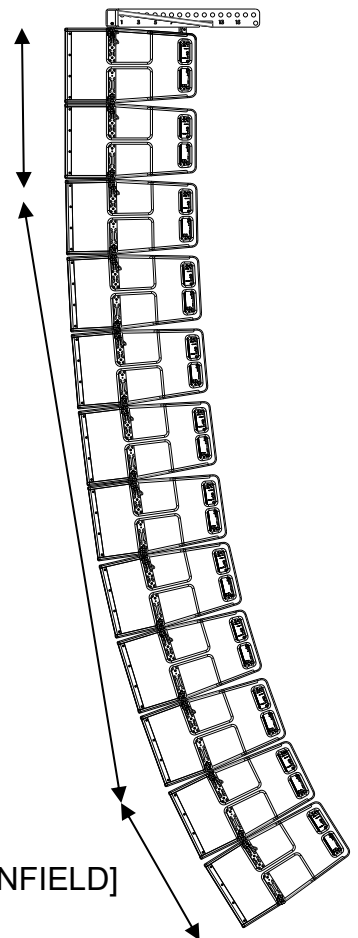
[HPF60  
LTHROW]

Model: X212AFD  
Preset: [HPF60 FLAT]

[HPF60 FLAT]

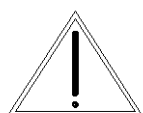
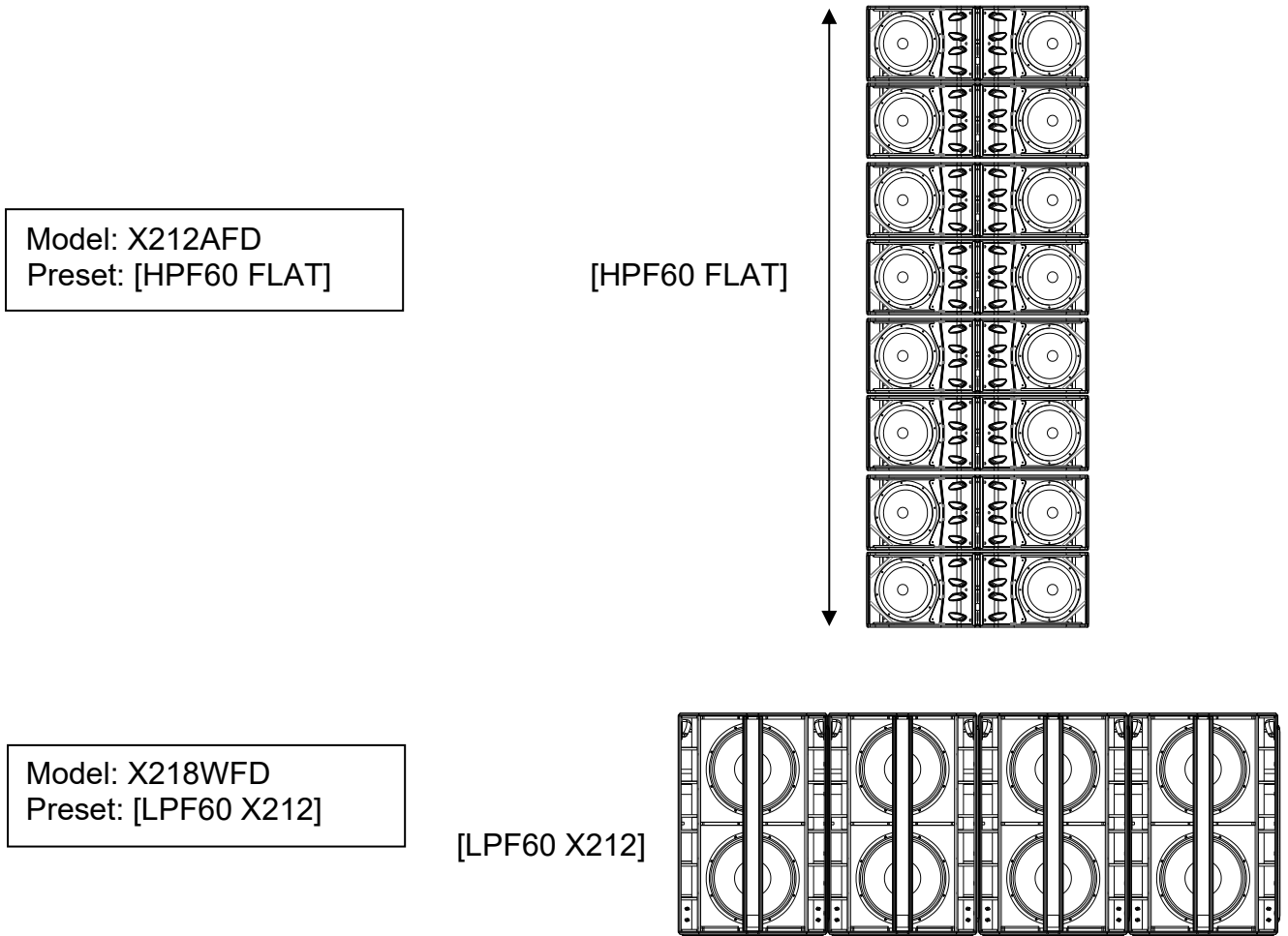
Model: X212AFD  
Preset: [HPF60 NEARFIELD]

[HPF60 NFIELD]



**3.3 Line source with X218WFD extension on floor and upper frequency limit of the subwoofer at 60 Hz.**

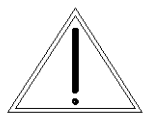
The X218WFD provides an extension of the bandwidth in the low end, down to 25 Hz. The system operates over the nominal bandwidth 25 Hz – 18 kHz, -10dB.



The minimum number of cabinets to be used as a line source system is 6 cabinets. We do not recommended to use less than 6 cabinets per side. The optimum number of cabinets per side would be from 8-9 cabinets to up.



Place the subwoofers side by side. If not possible, the maximum distance between two adjacent acoustic centres must be 2.8m when the upper frequency limit of the subwoofer is at 60 Hz.

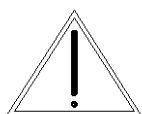
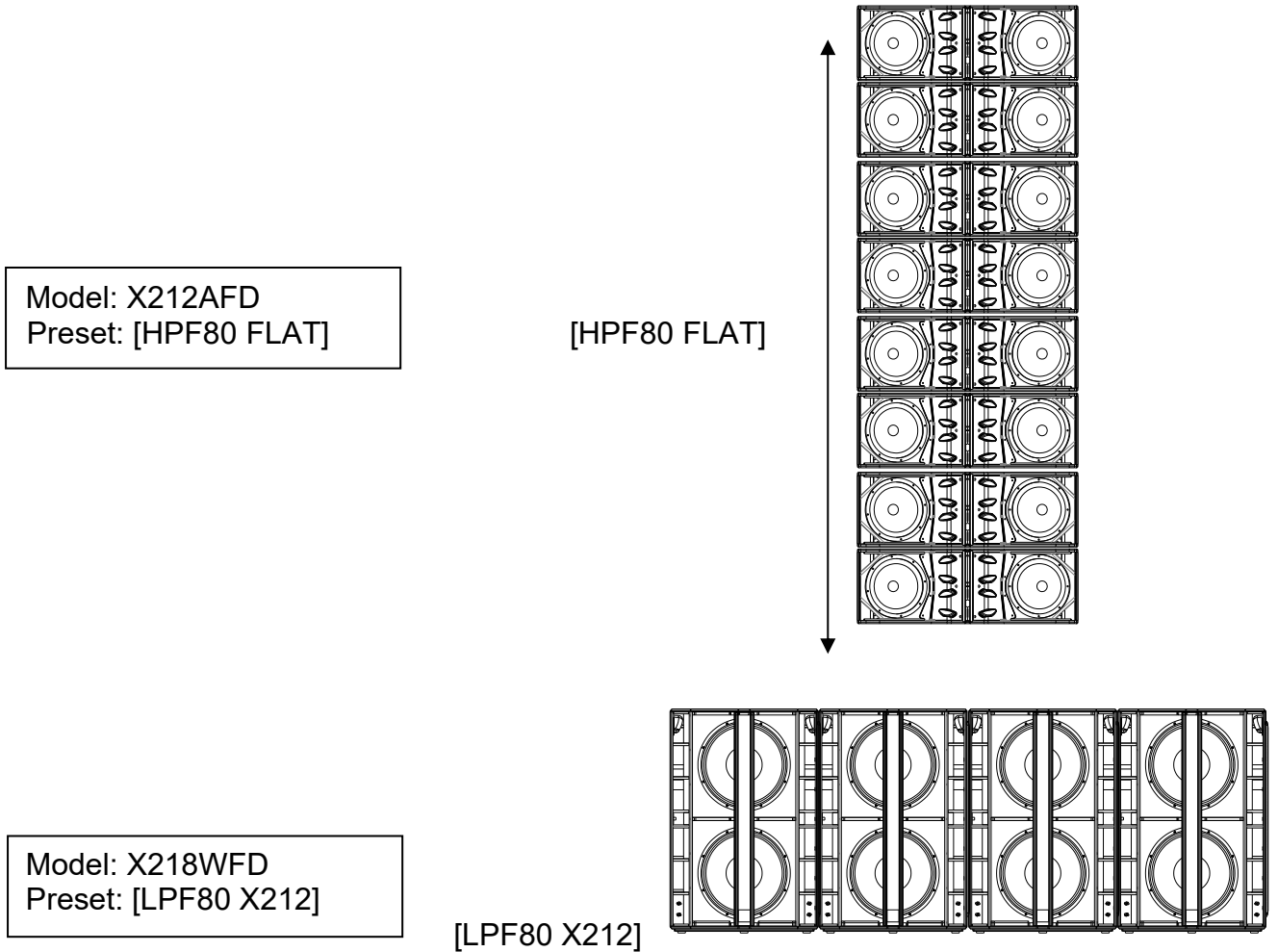


**SYSTEM ALIGNMENT**

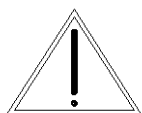
The system is pre-aligned from the factory. Do not forget to add the geometric delay depending on the configuration used.

**3.4 Line source with X218WFD extension on floor and upper frequency limit of the subwoofer at 80 Hz.**

The X218WFD provides an extension of the bandwidth in the low end, down to 25 Hz. The system operates over the nominal bandwidth 25 Hz – 18 kHz, -10dB.



The minimum number of cabinets to be used as a line source system is 6 cabinets. We do not recommended to use less than 6 cabinets per side. The optimum number of cabinets per side would be from 8-9 cabinets to up.



Place the subwoofers side by side. If not possible, the maximum distance between two adjacent acoustic centres must be 2.1m when the upper frequency limit of the subwoofer is at 80 Hz.

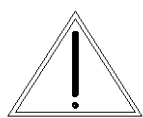
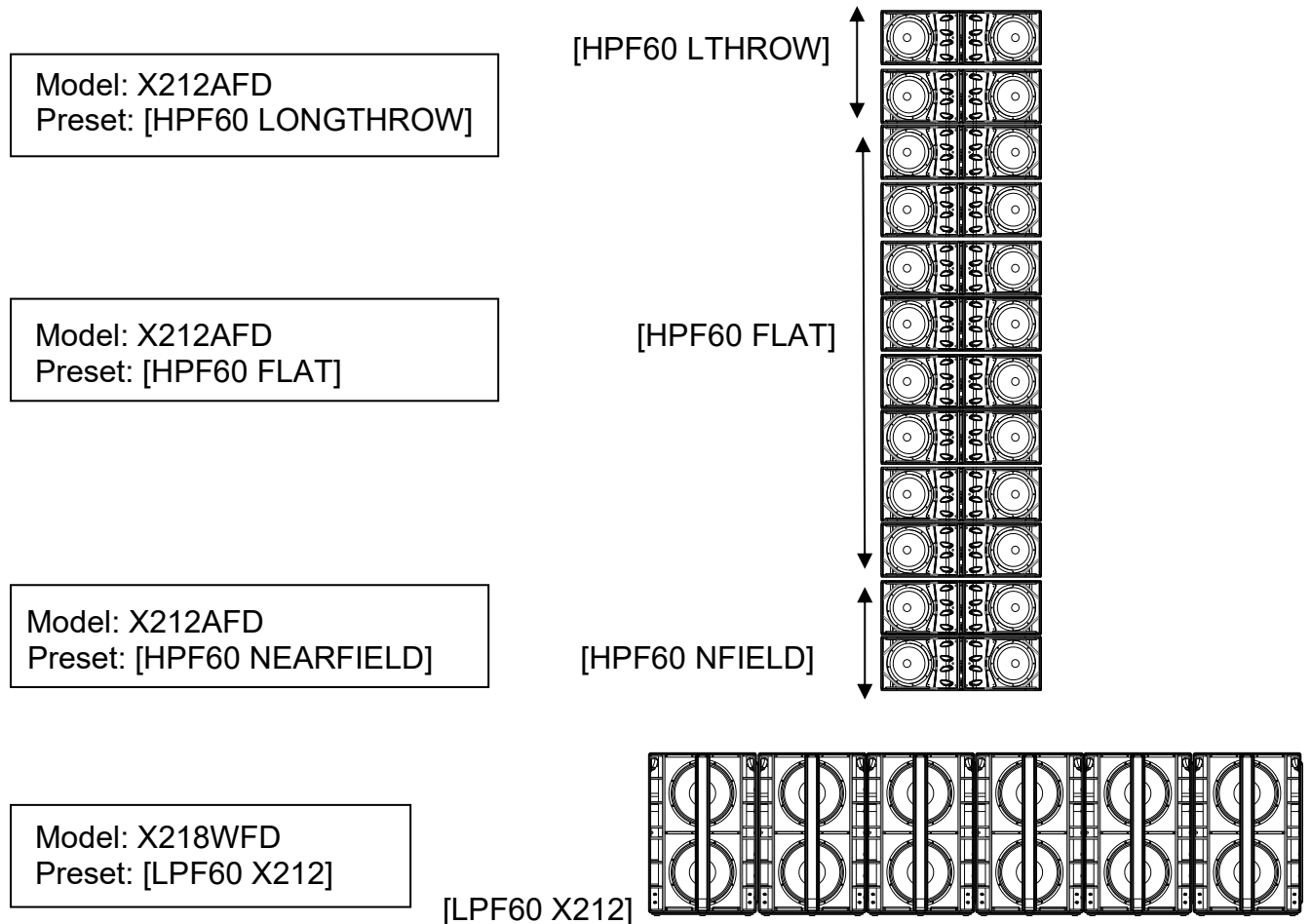


**SYSTEM ALIGNMENT**

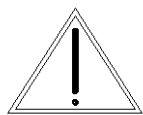
The system is pre-aligned from the factory. Do not forget to add the geometric delay depending on the configuration used.

**3.5 Line source (including NearField and Longthrow cabinets) with X218WFD extension on floor and upper frequency limit of the subwoofer at 60 Hz.**

The X218WFD provides an extension of the bandwidth in the low end, down to 25 Hz. The system operates over the nominal bandwidth 25 Hz – 18 kHz, -10dB.



The minimum number of cabinets to be used as a line source system is 6 cabinets. We do not recommended to use less than 6 cabinets per side. The optimum number of cabinets per side would be from 8-9 cabinets to up.



Place the subwoofers side by side. If not possible, the maximum distance between two adjacent acoustic centres must be 2.8m when the upper frequency limit of the subwoofer is at 60 Hz.

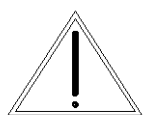
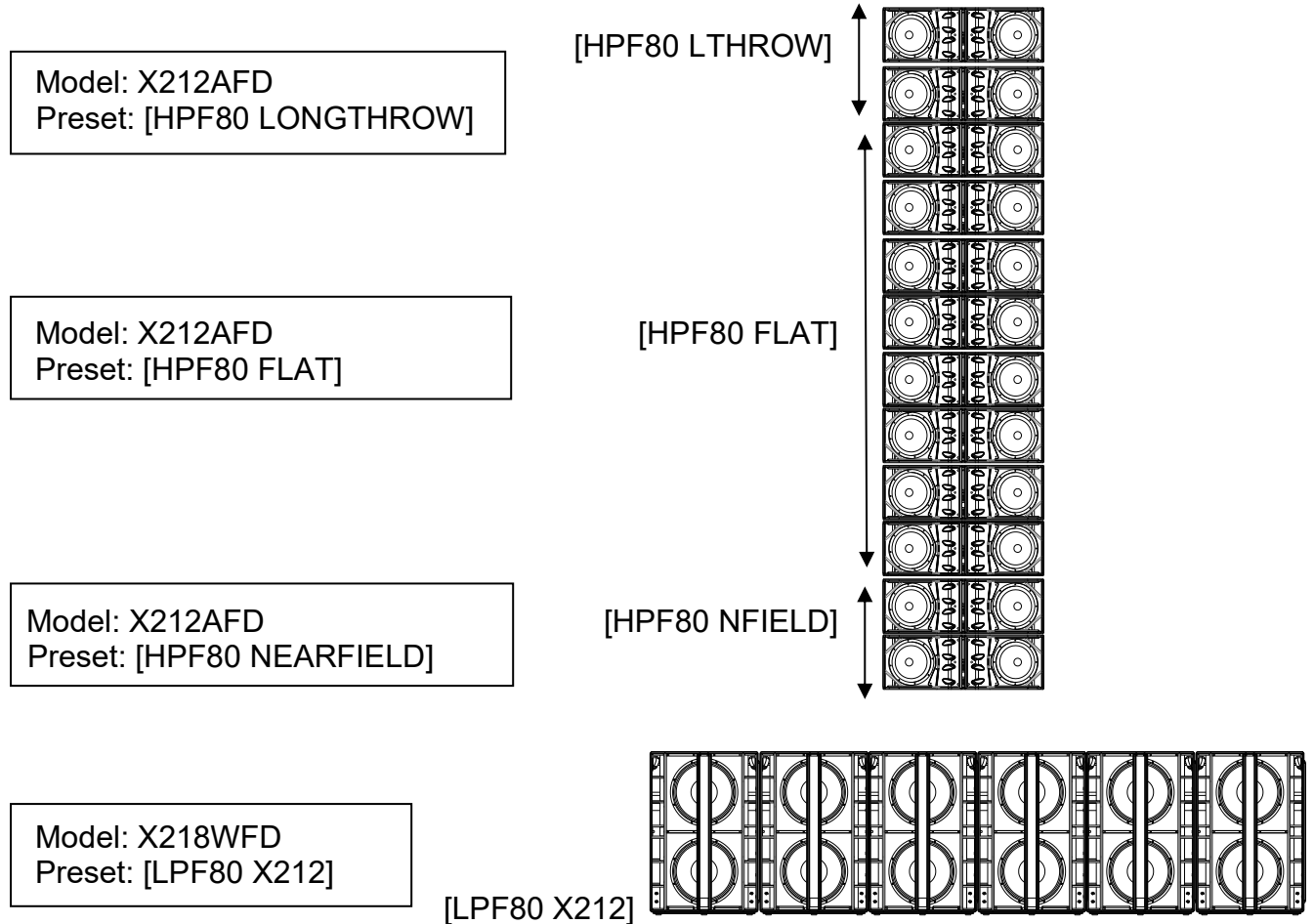


**SYSTEM ALIGNMENT**

The system is pre-aligned from the factory. Do not forget to add the geometric delay depending on the configuration used.

**3.6 Line source (including NearField and Longthrow cabinets) with X218WFD extension on floor and upper frequency limit of the subwoofer at 80 Hz.**

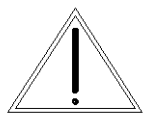
The X218WF/D provides an extension of the bandwidth in the low end, down to 25 Hz. The system operates over the nominal bandwidth 25 Hz – 18 kHz, -10dB.



The minimum number of cabinets to be used as a line source system is 6 cabinets. We do not recommended to use less than 6 cabinets per side. The optimum number of cabinets per side would be from 8-9 cabinets to up.



Place the subwoofers side by side. If not possible, the maximum distance between two adjacent acoustic centres must be 2.1m when the upper frequency limit of the subwoofer is at 80 Hz.



**SYSTEM ALIGNMENT**

The system is pre-aligned from the factory. Do not forget to add the geometric delay depending on the configuration used.

## 4 CONTROL AND CONNECTION PANEL

The X212AFD control panel contains the following elements:



Fig.9. X212AFD control and connection panel

**A) TOUCHSCREEN:** Displays information about the System status: current preset, network IP, amplifier temperature and signal input level. Allows the user to configure the system without the need of an external computer: IP address setting, Preset selection, Delay, Gain, Limiter, ECO mode on/off, Signal LEDs on/off, etc.

NOTE: The default PIN to access the setup menu is “1234”

**B) STATUS LEDs:** Report a special event happening in the system:

- **Protect:** (Red) A fault condition is being reported by the amplifier. If this LED is constantly lit even after resetting the device, please contact the technical service.
- **Standby:** (Orange) This led is lit when the equipment is set in Low Power consumption mode. This can be done via the touchscreen (ECOMode ON) or via PC. When ECOMode is in AUTO, the system will go into Standby after 5 minutes without signal at the input. When signal is present again, the system will go automatically into normal mode.
- **Mute:** (Red) The system is muted (amplifiers are disabled). The system can be muted from the PC remote control or from the touchscreen.

**IMPORTANT:** When the amplifier is in MUTE, the PROTECT LED will be also lit to show that the amplifier is disabled. Also when the system is waking up from the STANDBY mode, the PROTECT led will be lit for a few seconds. Under these circumstances the PROTECT LED is reporting that the amplifier is disabled, but not a fault condition.

**C) SIGNAL LEDS:** Indicate the status of the audio signal in the system:

- **Overload:** (Red) The input signal exceeds +14dBu (4Vrms), so the input compressor is engaging. Avoid the continuous lighting of this led in order to preserve the dynamic range of the audio signal.
- **Limiter:** (Orange) The output limiters of the system are being engaged. When this led blinks, the maximum power of the system is being reached. Avoid the continuous lighting of this led in order to preserve the dynamic range of the audio signal.
- **Input:** (Green) Signal is present at the input. This LED will light when the signal reaches -16dBu.

NOTE: The SIGNAL LEDs may be deactivated by selecting the option “LEDs OFF” in the PC software.

**D) AC INPUT/OVERVOLTAGE PROTECTION:** These LEDS show the status of the AC mains supply.

- **POWER ON:** (Blue) When lit, the equipment is ON and the AC input level is within the permitted range (up to 250 VAC).
- **>250V:** (Red) When activated, the AC voltage is permanently out of the permitted range of the equipment, so it will remain under protection until this condition is solved. Revise your connections and mains power installation and consider that other equipment connected to this line may have been damaged.

The connection panel has the following parts:

**E) NETWORK:** Two 8-pin RJ45 / EtherCon® compatible connectors for connection to Ethernet networks up to 1Gbps. This connection can be used for remote control via software (DSPStudio) and for audio signal input via Dante™ audio networking. Please refer to Amate Audio DSPStudio Quick Installation Guide for more information on remote connection. The two connectors are interconnected by means of an internal switch, so they can be used interchangeably and allow the chain connection of several boxes.

**IMPORTANT:** If Dante is used it is not recommended to chain more than eight units, due to latency reasons.

**F) BALANCED INPUT/LINK:**

XLR-3 Female balanced signal connector for signal input.

XLR-3 Male connector for parallel connection of various cabinets with the same input signal.

Nominal Input sensitivity: +8dBu (2 Vrms)

Maximum Input Voltage without input compression: +14dBu (4Vrms)

---



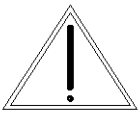
Maximum Input Voltage without clipping: +20dBu (8Vrms)

**IMPORTANT:** Please always use balanced microphone cable with the following pin assignment:

1= Shield (Ground) 2= Live (+) 3= Return (-)

**G) AC MAINS INPUT/LINK:** Mains supply connection via PowerCon.

- Blue connector for AC in.
- Grey connector to feed other units in parallel. Linking up to three units is possible, provided that a quality cable of a minimum section of 3x2.5mm<sup>2</sup> is used. Connecting more than three units in parallel may lead to a voltage drop in the cable that will reduce the equipment performance.



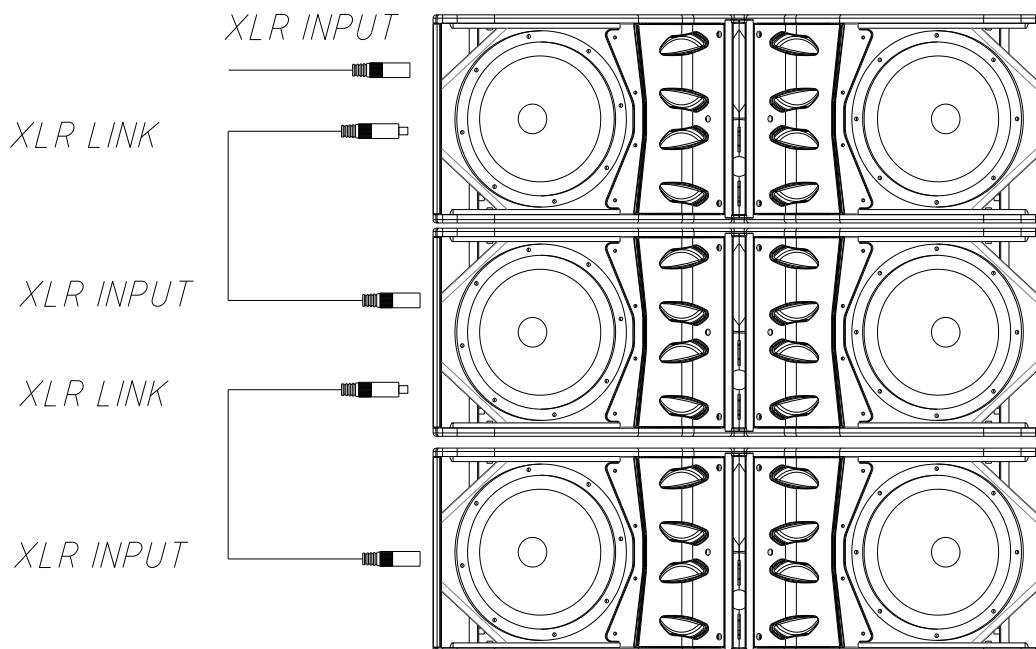
Always use mains power cable supplied by manufacturer.  
Never connect the Xcellence cabinets to an unearthed mains supply or by using an unearthed mains cable.

## 5 CONNECTING

### 5.1 Parallel connection

#### 5.1.1 Analog Audio Signal

Connect the signal (mixing desk output) to INPUT on the first unit. Use the LINK output to transfer the INPUT signal to the second unit and thus sequentially for further units. All of the units in this chain must be switched on.



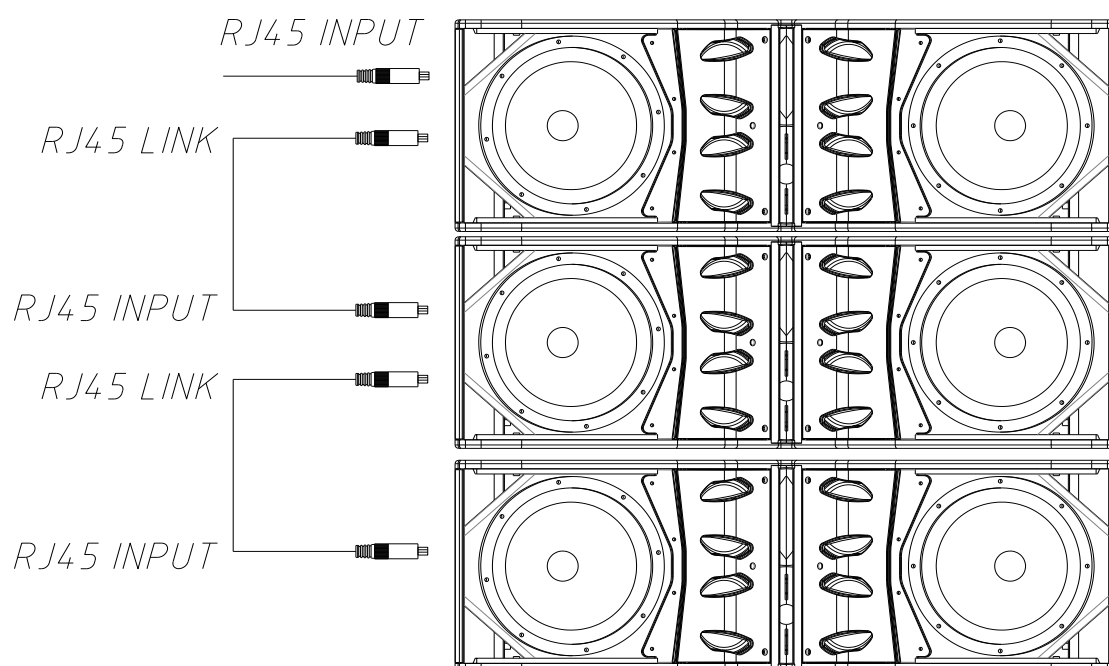
**Fig.10.** Parallel connection for the X212AFD (signal). You can link three units or more

### 5.1.2 Network

The two available Ethernet ports via the EtherCon RJ-45 connector are internally switched and both can be used as input and link to other cabinets. All of the units in this chain must be switched on.

The number of units allowed in parallel or daisy-chain depend on whether Dante audio networking is being used.

When using Dante, a maximum number of 8 cabinets is recommended due to latency reasons. When not, there is no specific limit for daisy-chaining (control and monitoring using DSPStudio®).



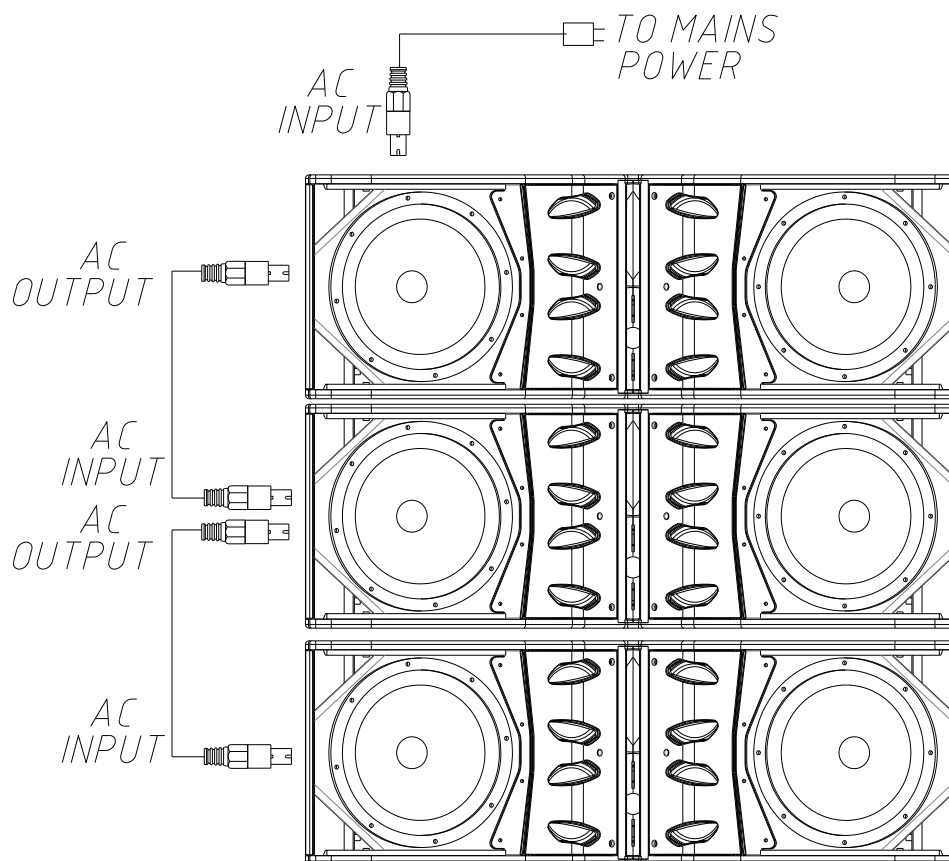
**Fig.11.** Parallel connection for the X212AFD (network). You can link up to eight units when using Dante networking, or more when not using it.

### 5.1.3 Mains Power

For the mains connection in parallel use the cable with grey Neutrik PowerCon NAC3FCB at one end and the blue Neutrik PowerCon NAC3FCA at the other end.



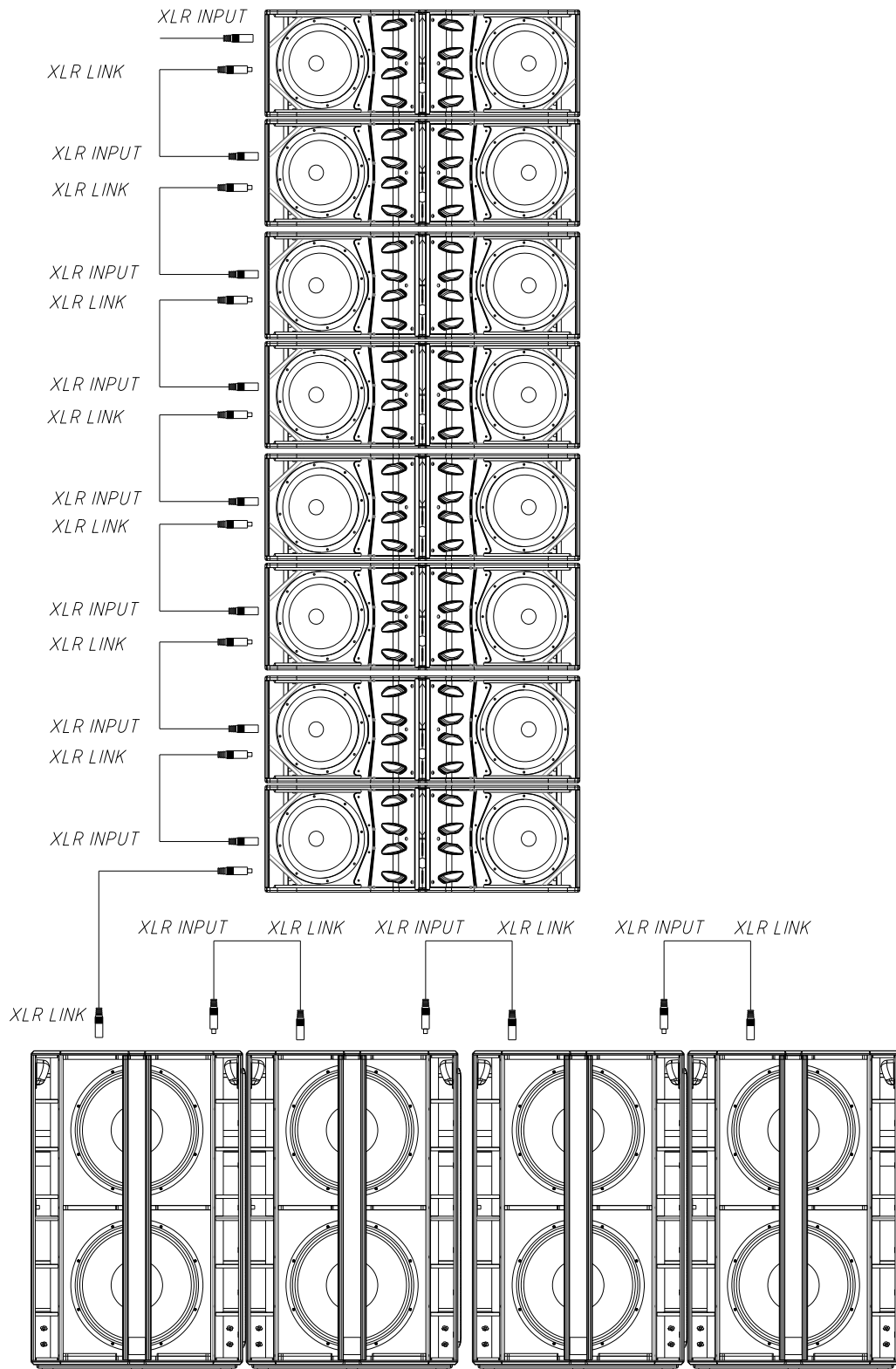
Do not connect more than three X212AFD units using the AC Mains link connector. Do not connect Xcellence series units in parallel using PowerCon-PowerCon without earth.



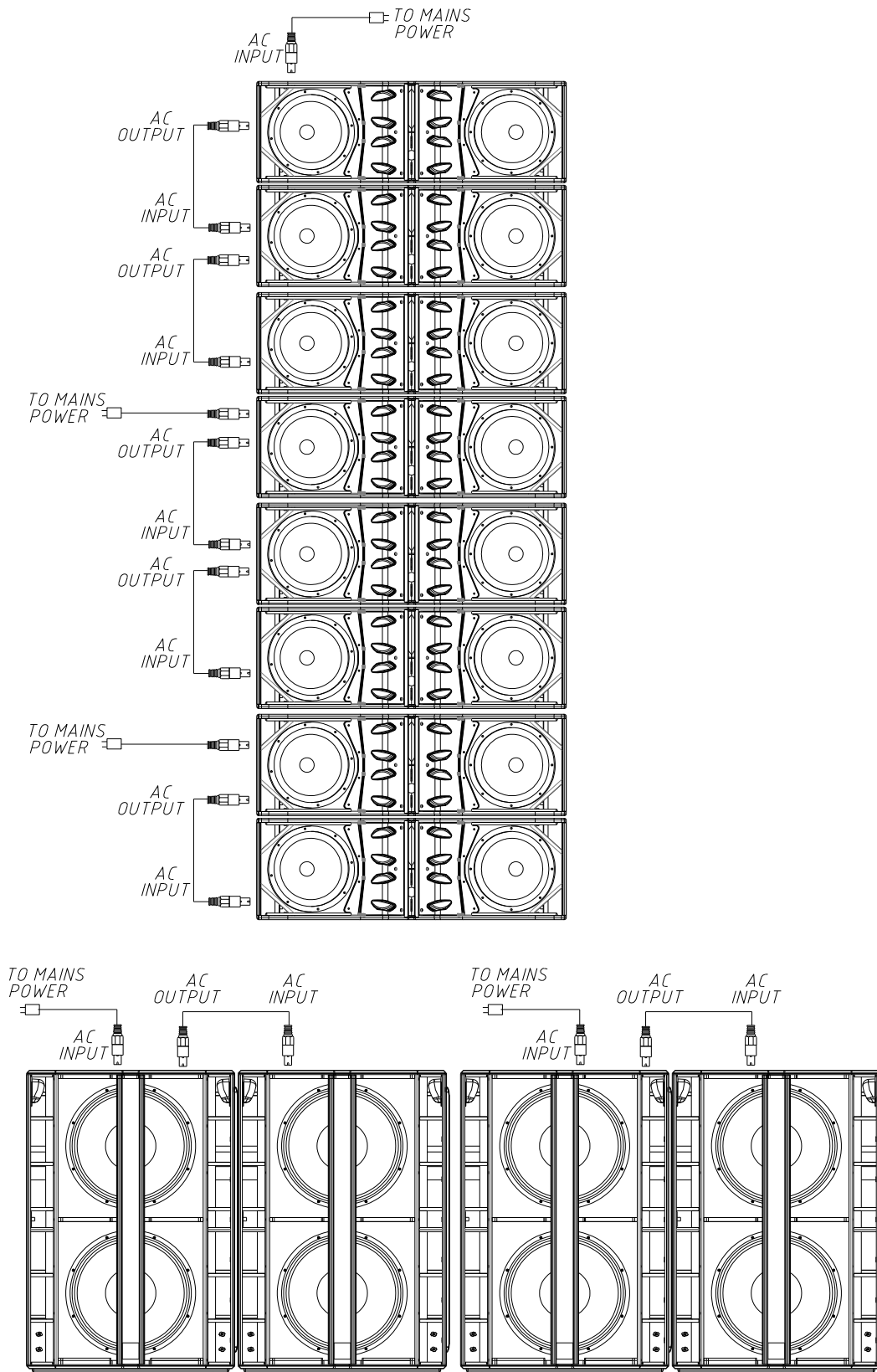
**Fig.12.** Parallel connection for the X212AFD (mains). You can link up to three units

### 5.2 Parallel connection with subwoofers

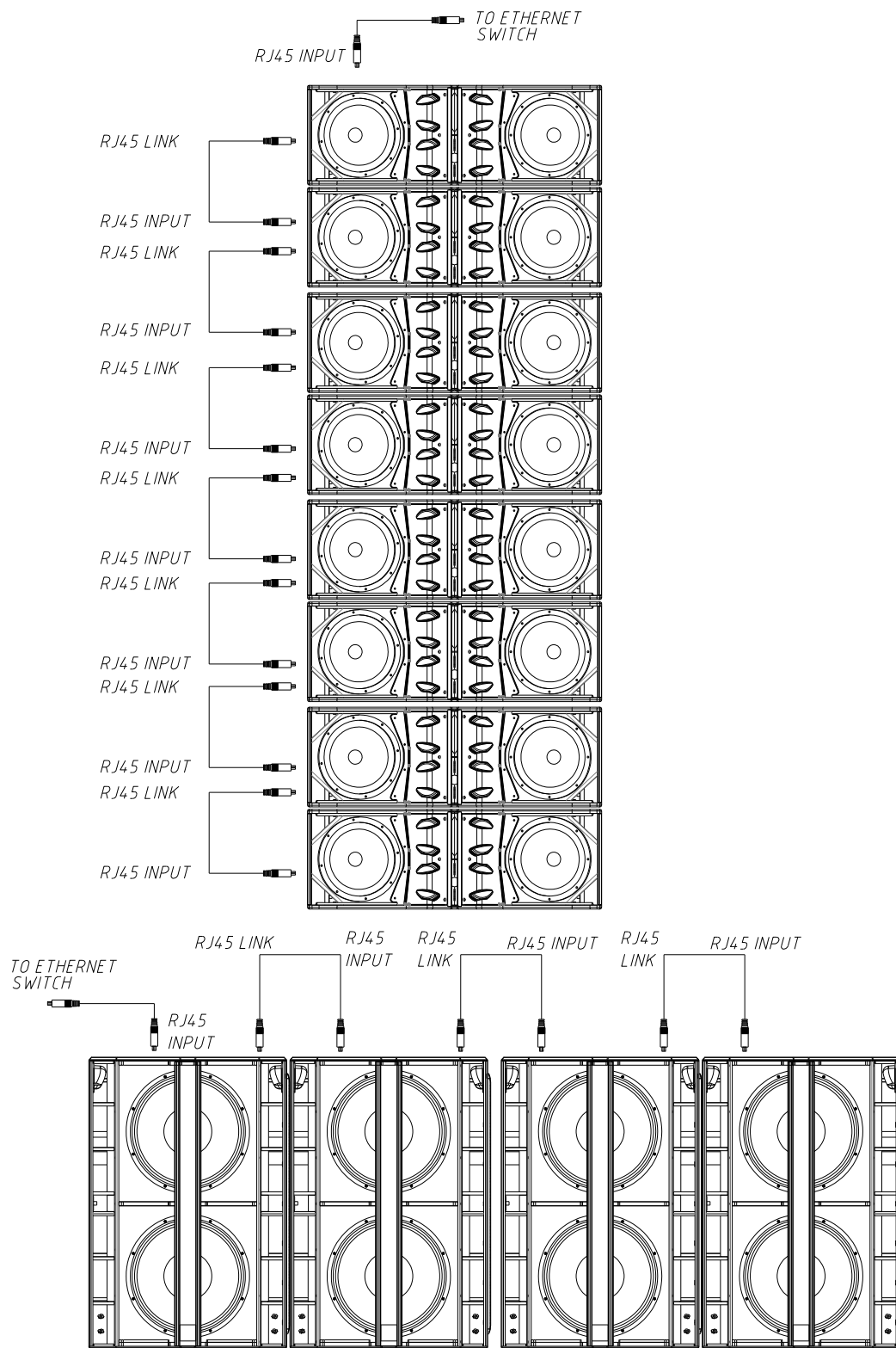
You can connect the X212AFD in parallel with X218WFD subwoofers or other units. Please, follow the same parameters as explained in the following diagrams:



**Fig.13.** Parallel connection for the X212AFD and X218WFD (signal)



**Fig.14.** Parallel connection for the X212AFD and X218WFD (mains). Do not connect more than three units of X212AFD or two units of X218WFD using the AC Mains link connector.



**Fig.15.** Parallel connection for the X212AFD and X218WFD (network). Do not daisy-chain more than eight units of each when using Dante networking (as in the diagram).

## 6 OVERVOLTAGE PROTECTION

The active Xcellence series models incorporate an exclusive protection by Amate Audio against mains voltage overload and other related problems (loss of neutral, connection between phases, etc.). In the mains input an electronic circuit compares the input voltage with a reference value. When the input exceeds 250 Volts, the circuit reacts by blocking the input tension until it returns to its correct limits (230V +/- 10%). When the overvoltage LED lights up red, the unit stops running, until the correct voltage is re-established.

Generally the cause of such an anomaly tends to be a neutral voltage drop or incorrect connection of the equipment to 400V supply. Whenever the overvoltage LED lights up, check the tension of the electrical phases: other devices in the sound system are also at risk of electrical fault and severe damage.

## 7 MOUNTING AND INSTALLATION

Flying an X212AFD system is easy, fast and secure. To perform any operations related to flying the system, read the present document, and act on the warnings and advice given.

Only experienced installers with adequate knowledge of the system and local safety regulations should fly speaker cabinets.

It is the user's responsibility to ensure that the systems to be flown and the flying accessories (such as chains, eyebolts, lock pins...) comply with state and local regulations. They should be regularly inspected and replaced if in doubt.

When flying enclosures from ceiling support structures, extreme care should be taken to assure the load bearing capabilities of the structures. **Do not fly systems from unsafe structures.**

All flying accessories that are not supplied by Amate Audio are the user's responsibility. Use at your own risk.

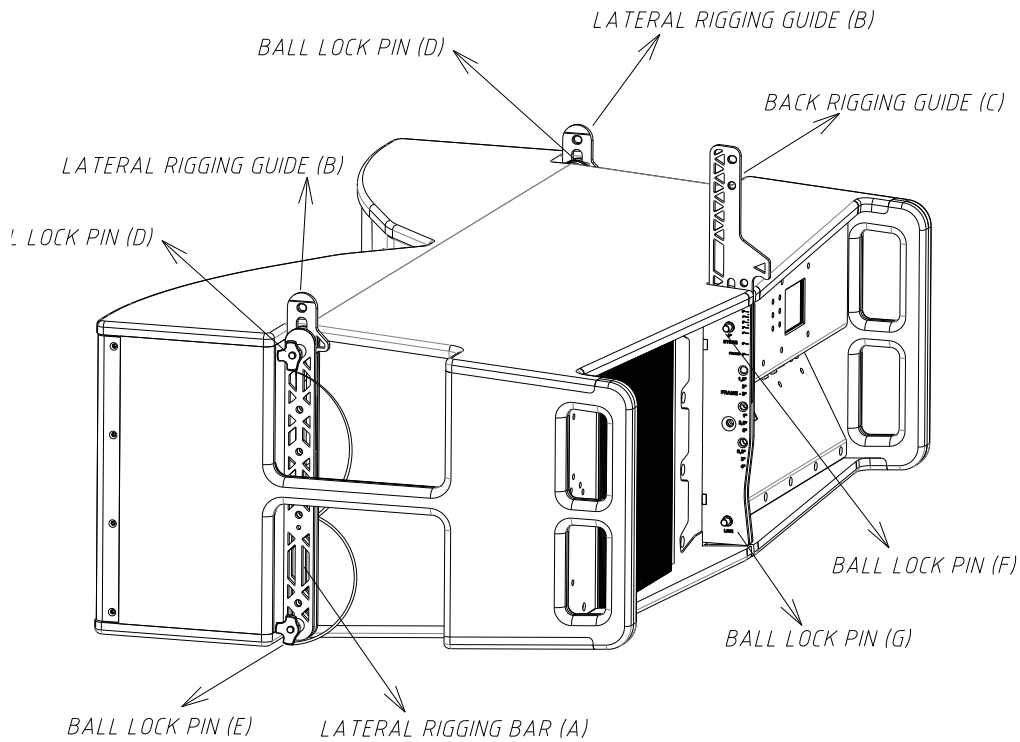
**Remember that no risks should be taken with regards to public safety.**

### 7.1 Description

Each X212AFD cabinet includes two rigging bars, one on each side of the enclosure (A). These structures are manufactured from stainless-steel; they are affixed to some internal plates with special crop resistant screws. There are two guides (B), inside each of the rigging bars, which are used to join the cabinets.

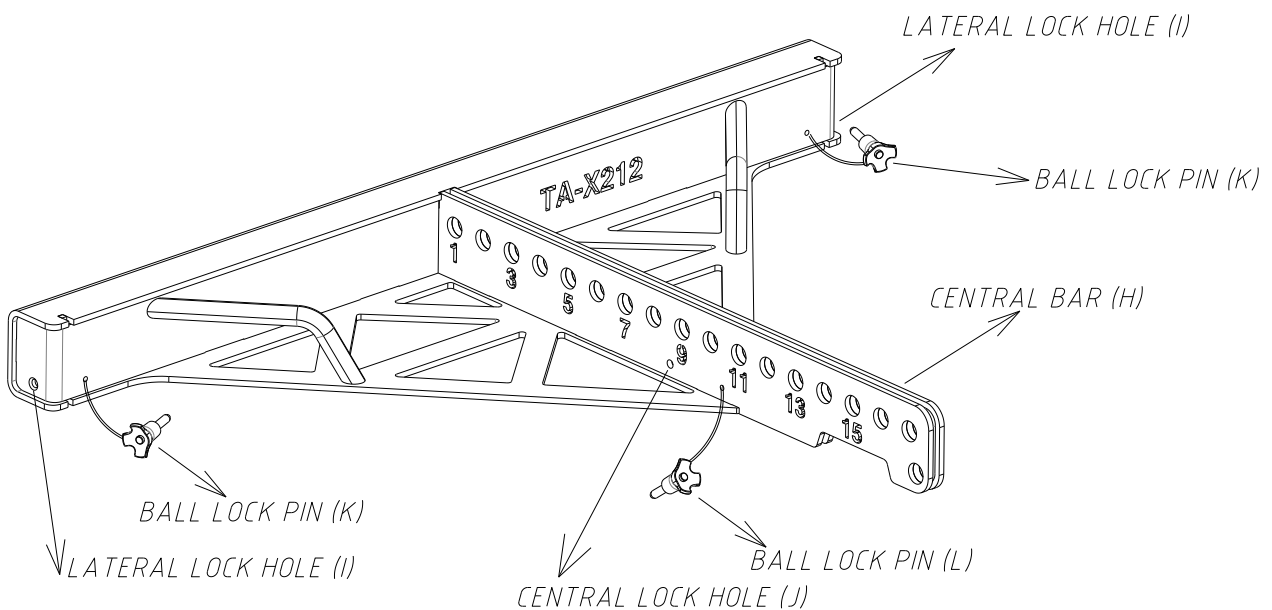
A third back guide (C), assembled on the back side of the cabinet, is used to vertically join the cabinets and to tilt them.

Angles can be changed from 0° to 8°. To safely lock the rigging bars, the lock pins (D), (E), (F), (G) supplied must be used.



**Fig.16.** In-built flying hardware (lateral and back view)

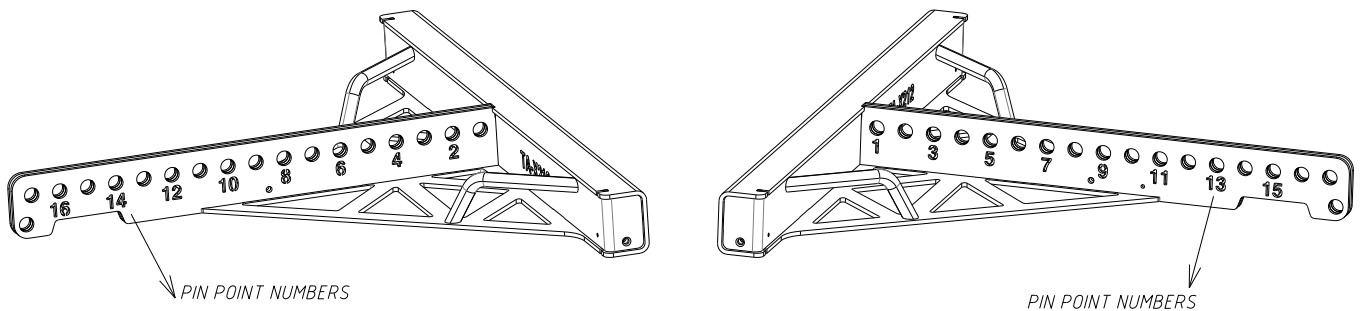
To fly X212AFD units use the TA-X212 stainless-steel frame. It includes a central bar to reinforce the whole structure (H). The bar includes several holes that provide a pickup point for the steel chain slings or the hoists. The pickup point chosen will determine the tilt angle of the whole array system. The TA-X212 also includes two lateral lock holes (I) to be attached to the X212AFD lateral rigging guides and one central lock hole (J) to be attached to the X212AFD back rigging guide. To safely lock the frame, the lock pins (K) and (L) supplied must be used.



**Fig.17.** TA-X212 flying frame



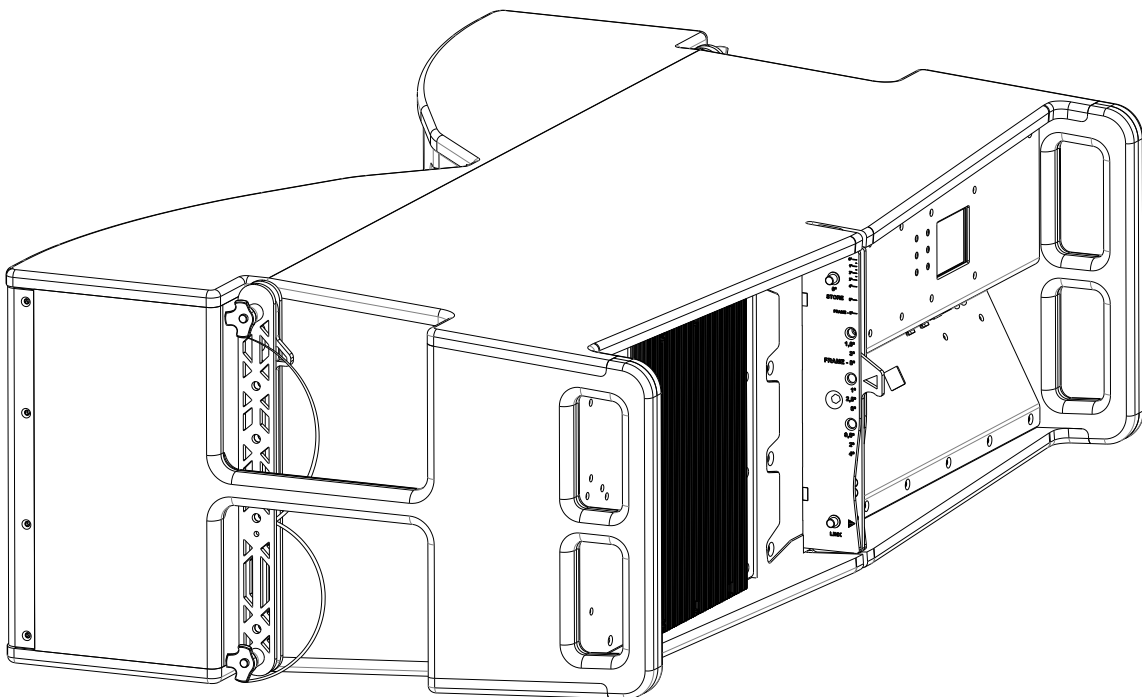
The numbers on the central bar are those corresponding to Ease Focus calculations.

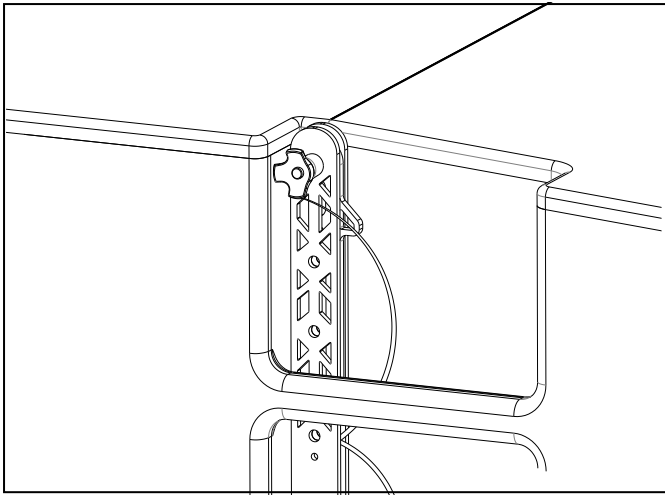


**Fig.18.** Pin points on TA-X212

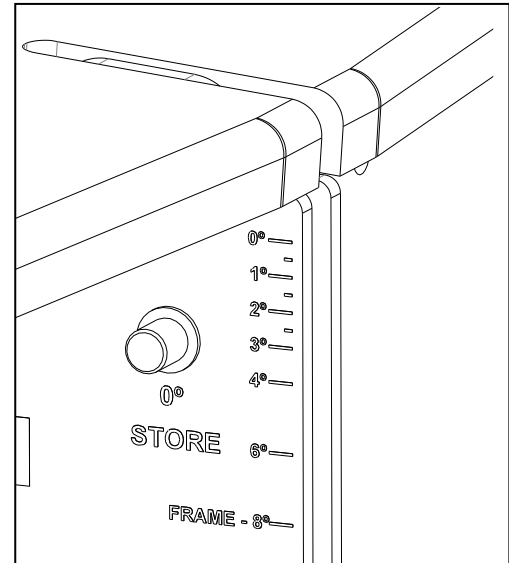
## 7.2 Vertical Flying

- On its “STORE” position, both the lateral rigging guides (left and right) and the back rigging guide are hidden and locked with their ball lock pins.



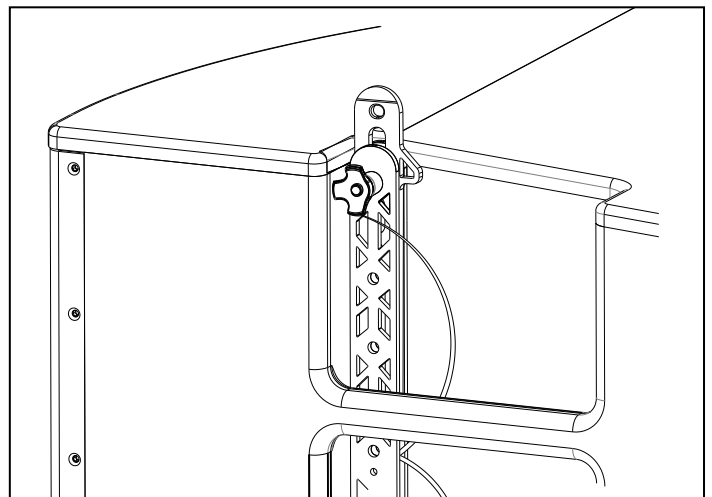
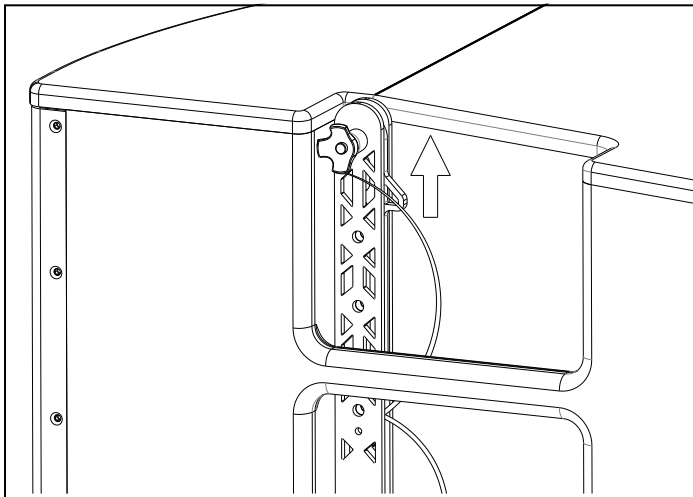


**Fig.19.** "STORE" lateral position



"STORE" back hole

- Release both the left and right ball lock pins of the first cabinet and let the inner guides go up. Then, block the guides by putting the ball lock pins.



**Fig.20.** Release of the lateral rigging guides of X212AFD (first cabinet)

Release the back ball lock pin of the first cabinet and let the inner back guide go up. Then, block the guide by putting the ball lock pin. First point the arrow to "FRAME" mark and then put the lock pin on "FRAME" hole.

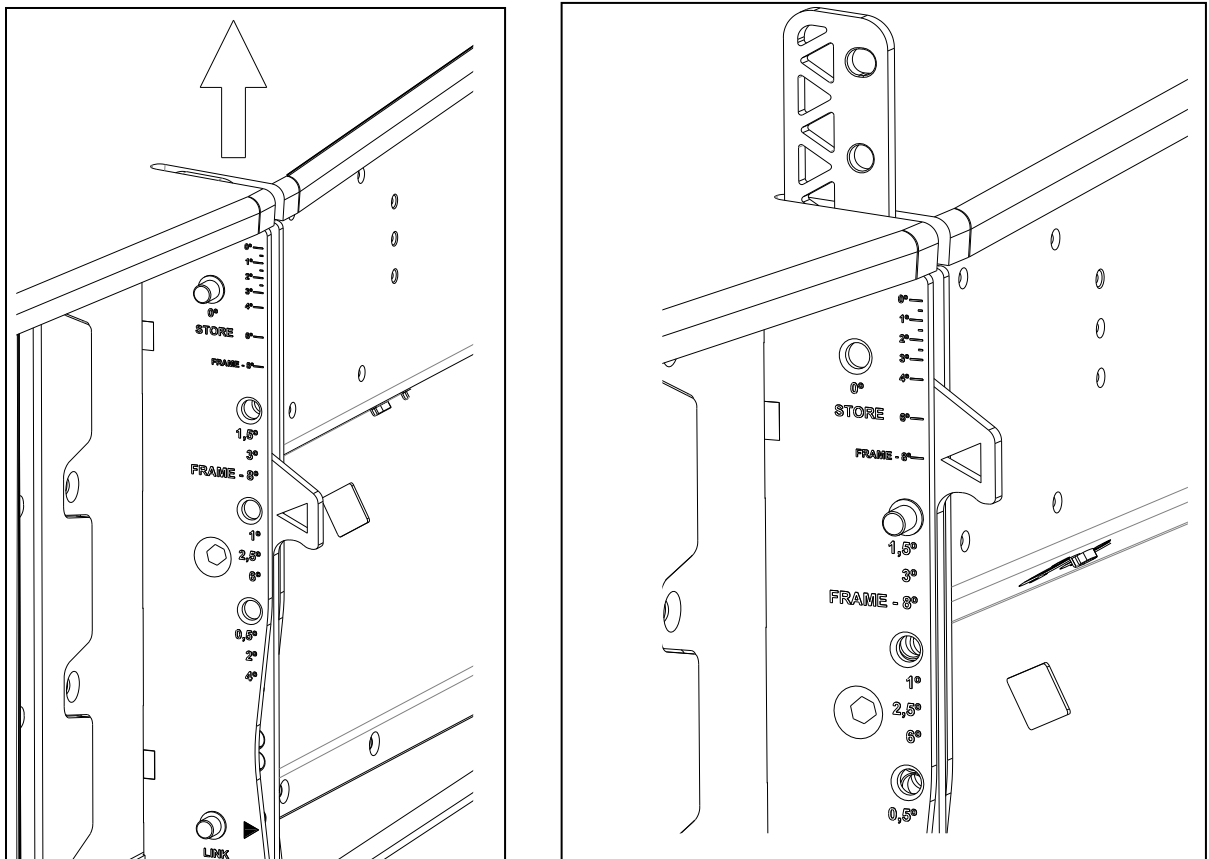


Fig.21. Release of the back rigging guide of X212AFD (first cabinet)

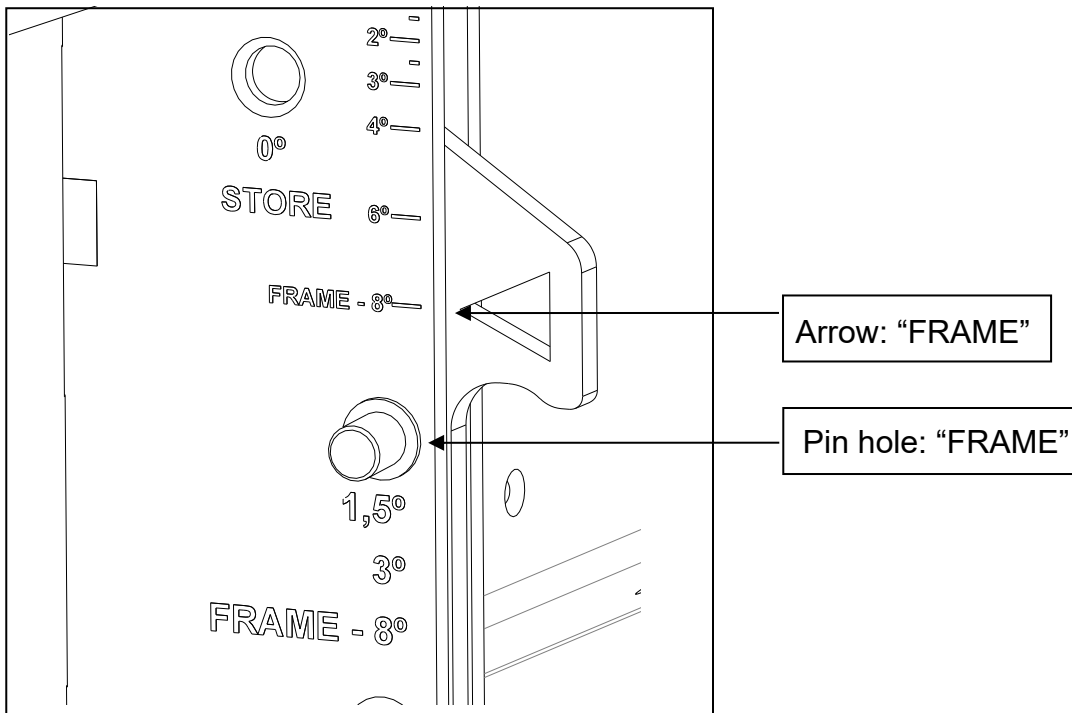
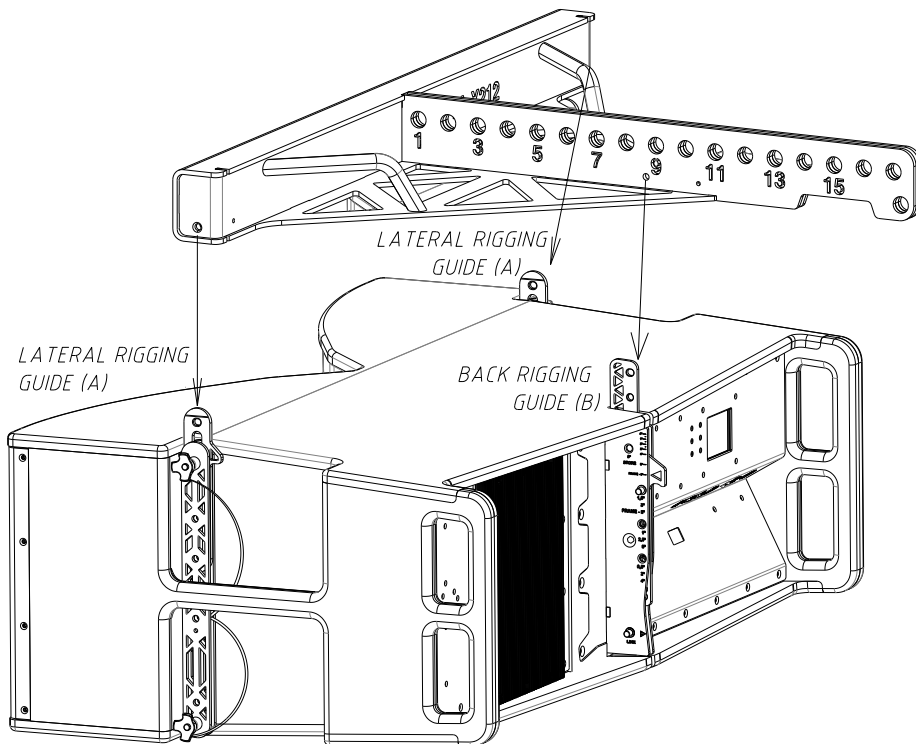


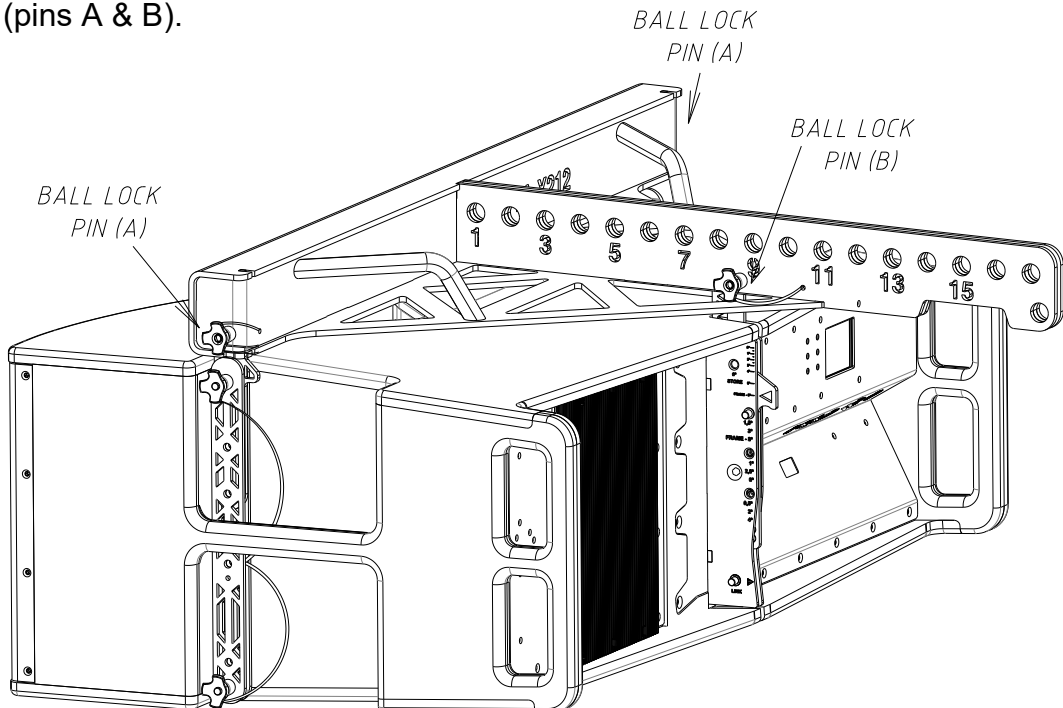
Fig.22. Arrow position and pin hole position (first cabinet)

- Place the array frame (TA-X212) on top of the first cabinet to be received by the X212AFD left & right lateral rigging guides (A) and the back rigging guide (B).



**Fig.23.** TA-X212 frame and X212AFD cabinet (first cabinet)

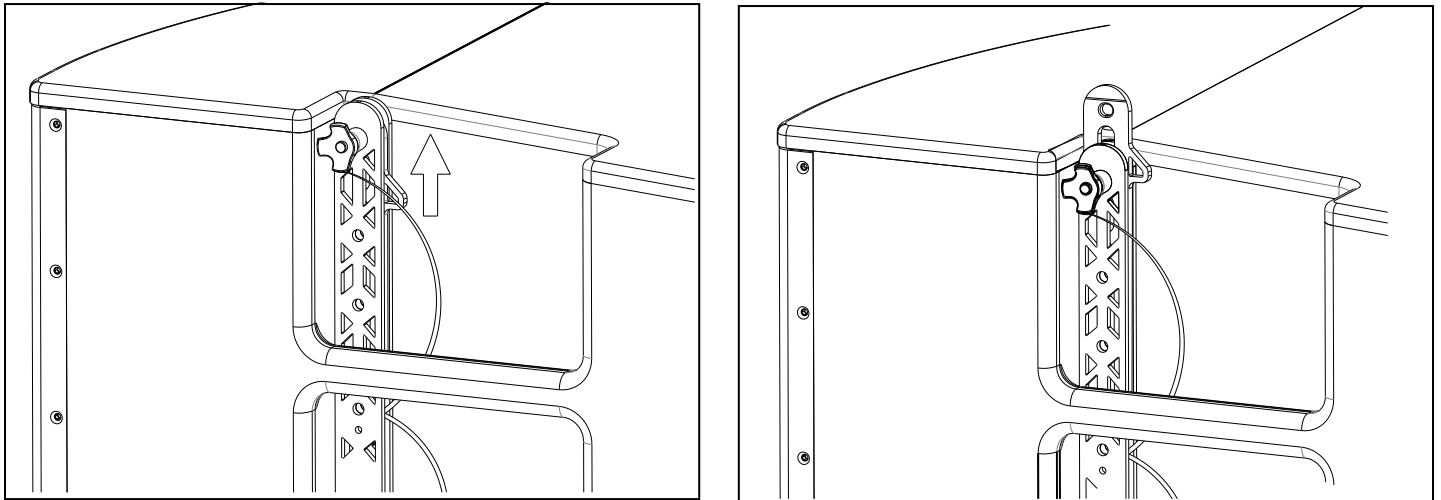
- Once the frame is received by the X212AFD lateral and back rigging guides, use the provided ball lock pins on the TA-X212 to attach the frame to the cabinet (pins A & B).



**Fig.24.** TA-X212 attached to X212AFD (first cabinet)

Any time two or more X212AFD are arrayed together, they must be mechanically secured to each other using the in-built rigging lateral guides, rigging back guide and supplied ball lock pins.

- Release both the left and right ball lock pins of the second cabinet and let the inner guides go up. Then, block the guides by putting the ball lock pins.

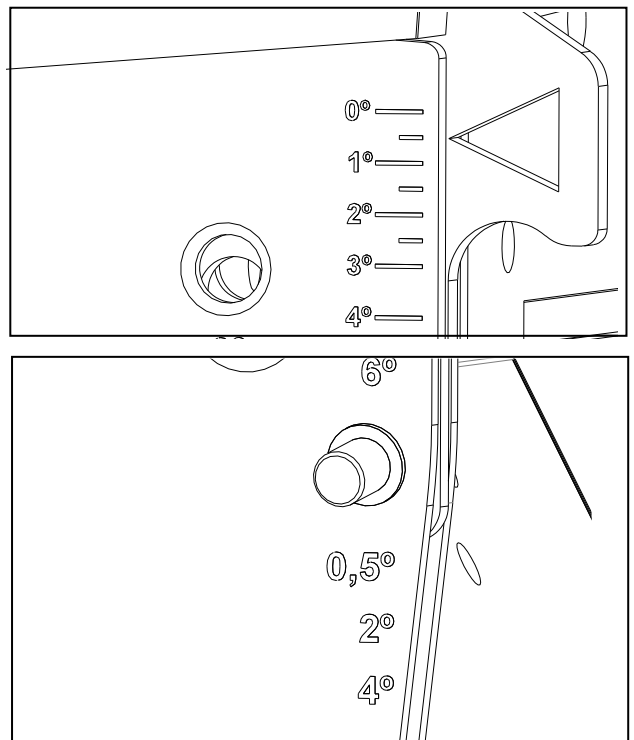
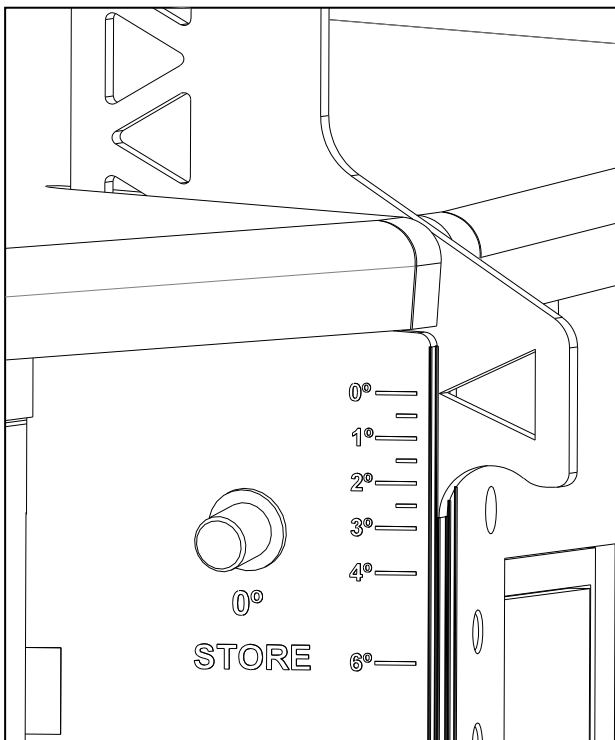


**Fig.25.** Release of the lateral rigging guides of X212AFD (second cabinet)

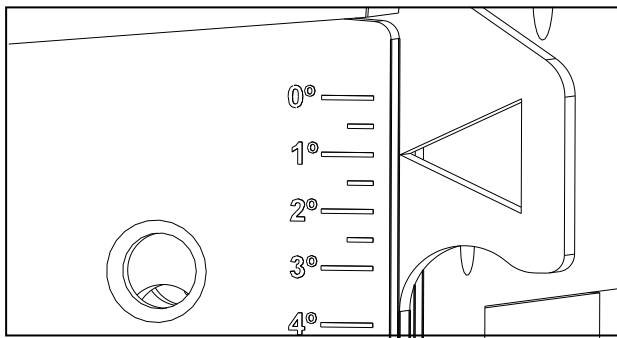
- Choose the desired tilting angle. Release the back ball lock pin of the second cabinet and let the inner back guide go up. Then, block the guide by putting the ball lock pin. Point the arrow to the desired angle mark and then put the lock pin on the desired angle hole.

Arrow mark 0° / Pin hole 0°

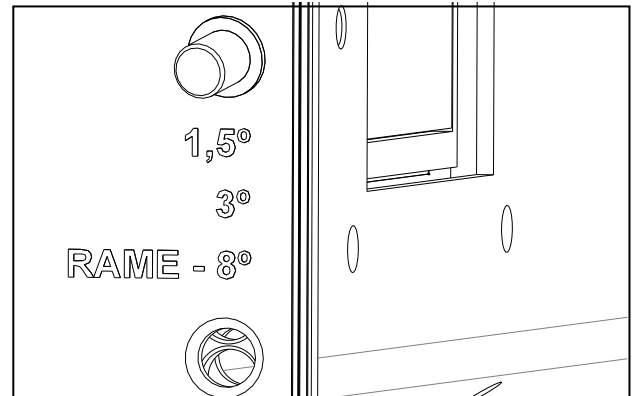
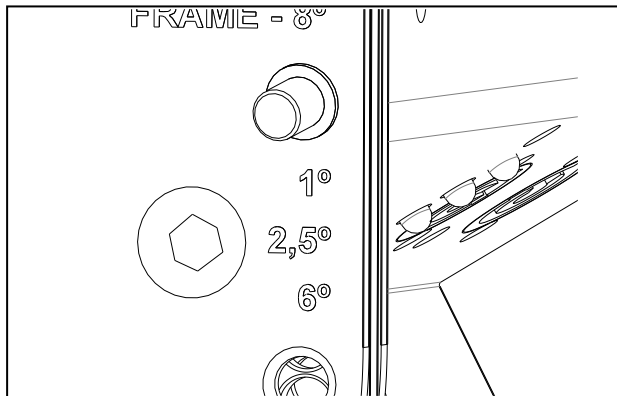
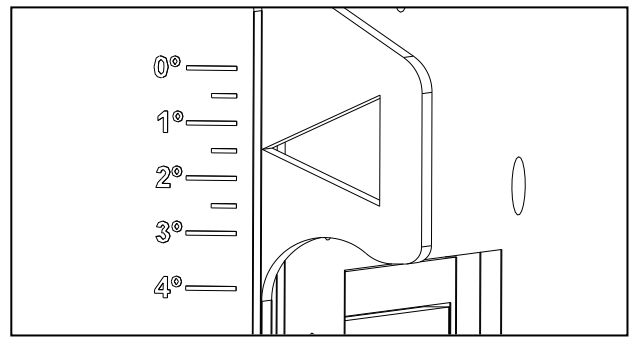
Arrow mark 0.5° / Pin hole 0.5°



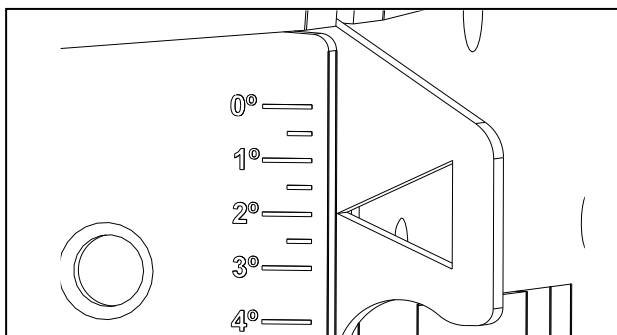
Arrow mark 1° / Pin hole 1°



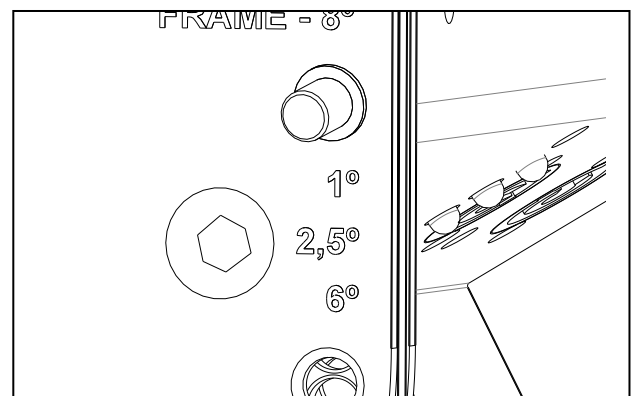
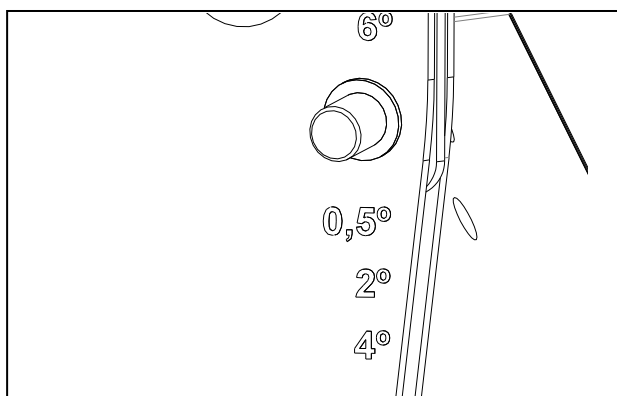
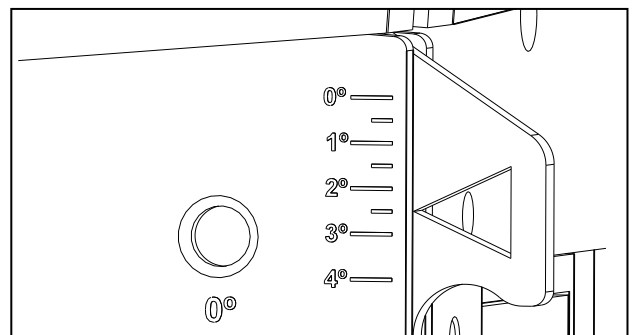
Arrow mark 1.5° / Pin hole 1.5°



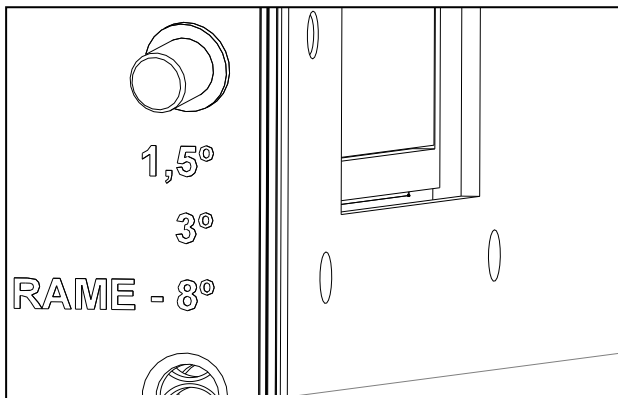
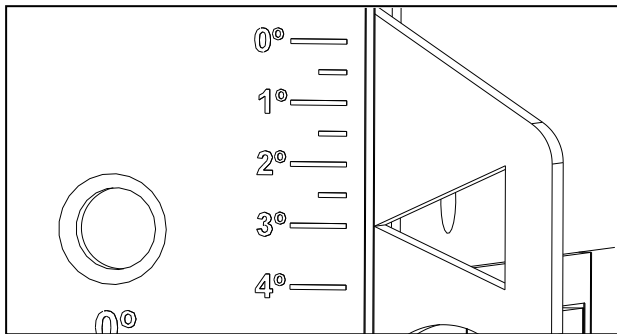
Arrow mark 2° / Pin hole 2°



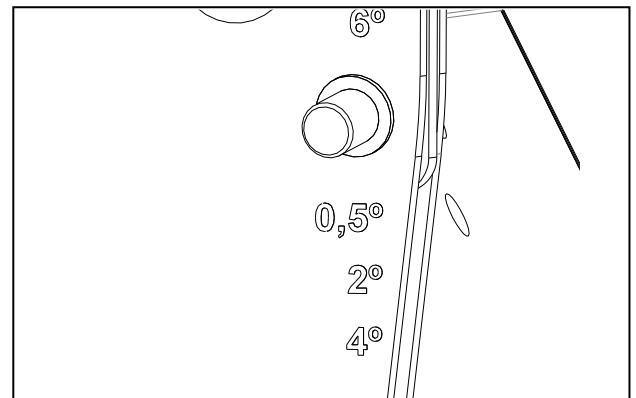
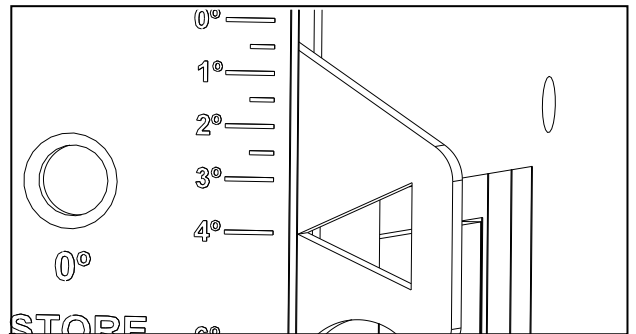
Arrow mark 2.5° / Pin hole 2.5°



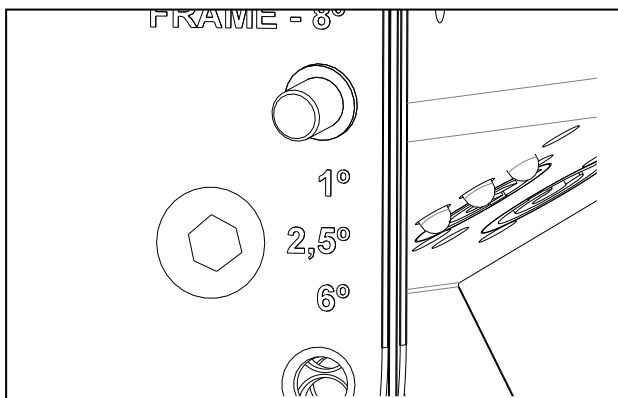
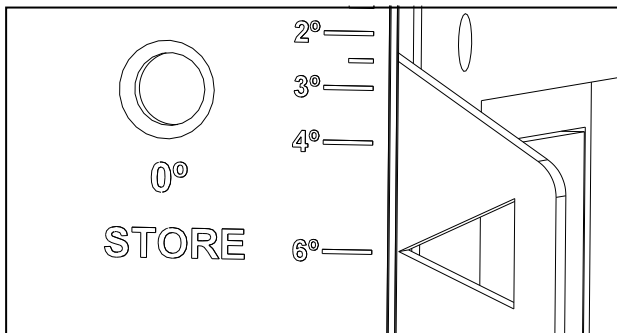
Arrow mark 3° / Pin hole 3°



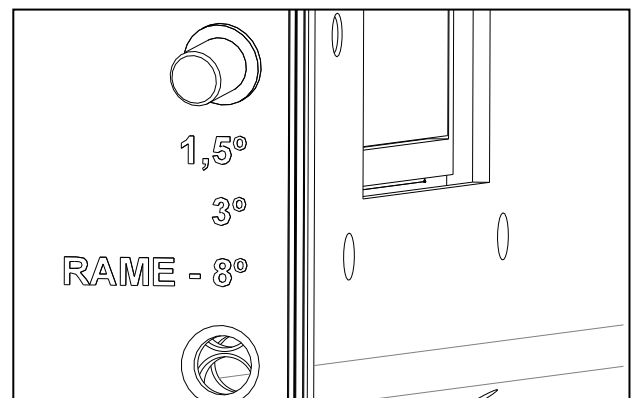
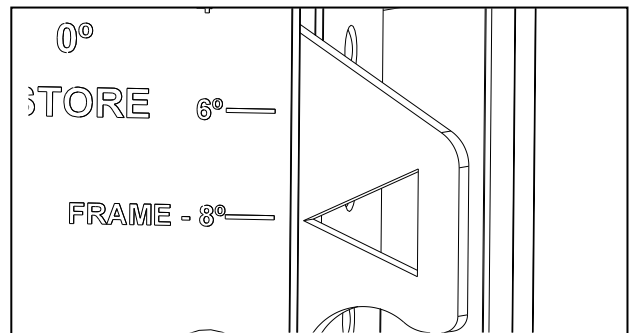
Arrow mark 4° / Pin hole 4°



Arrow mark 6° / Pin hole 6°

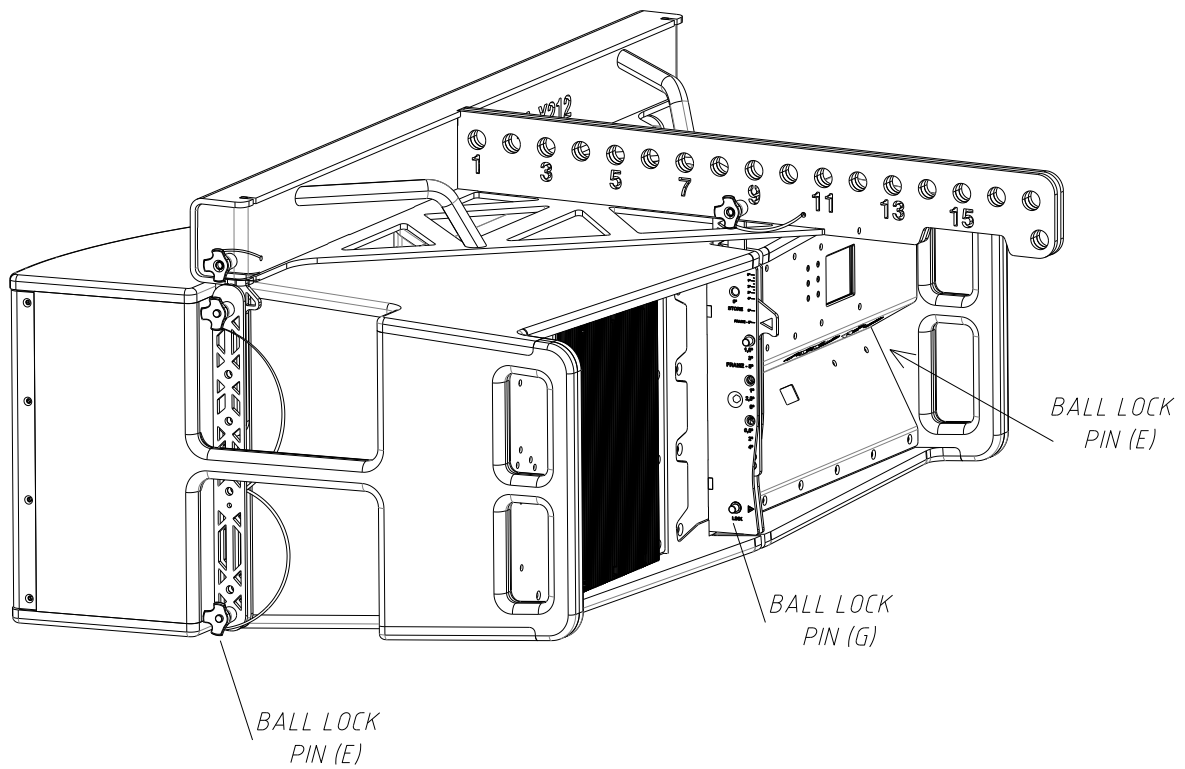


Arrow mark 8° / Pin hole 8°

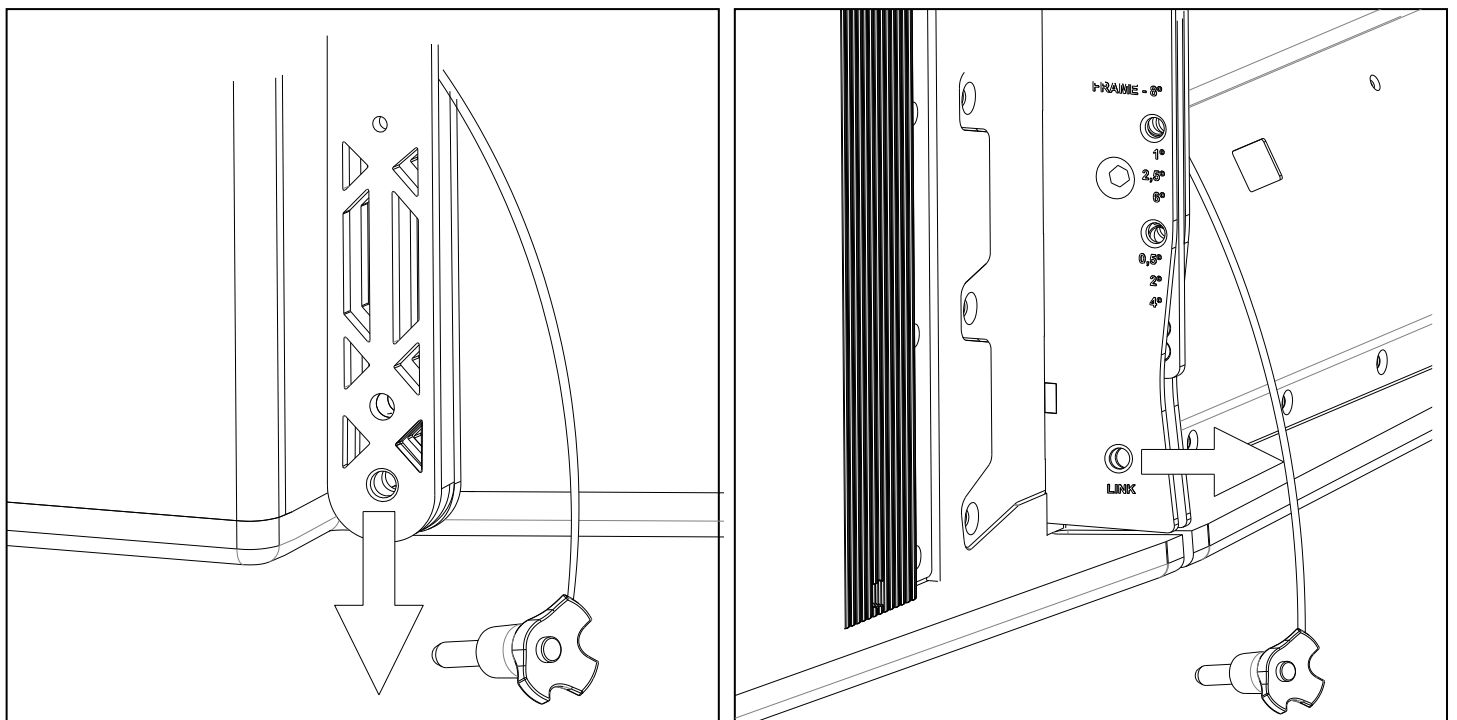


**Fig.26.** Choose the desired tilting angle

- Release the pins (E left), (E right) and (G back) from the first unit.



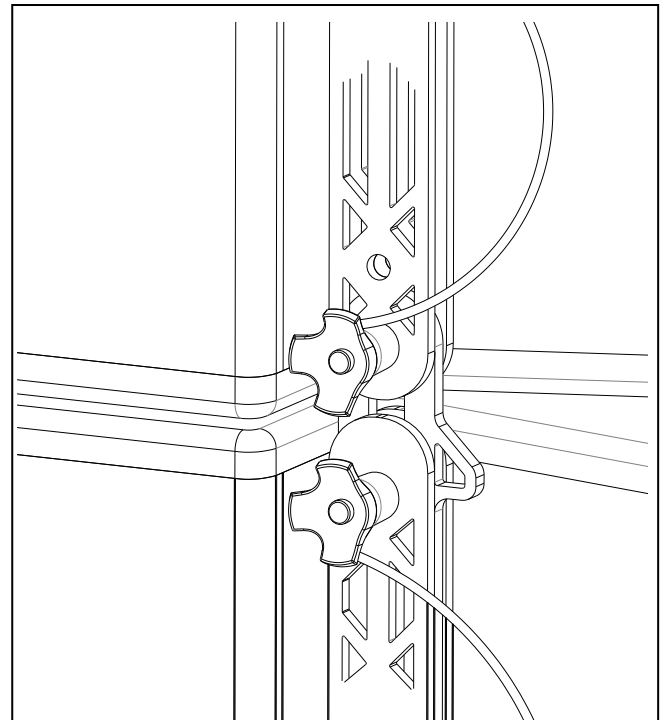
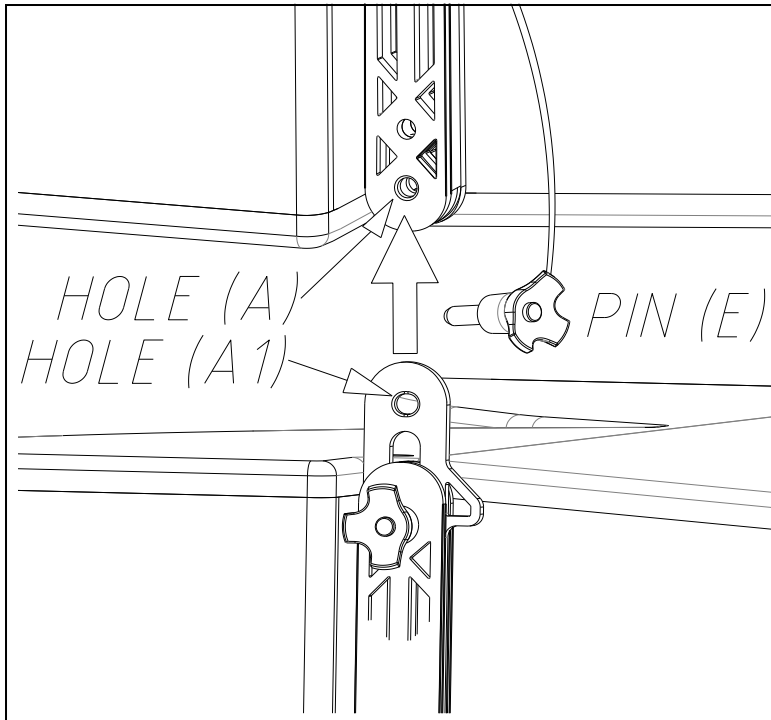
**Fig.27.** Release pins (E) and (G) from first cabinet



**Fig.28.** Release pins (E) and (G) from first cabinet

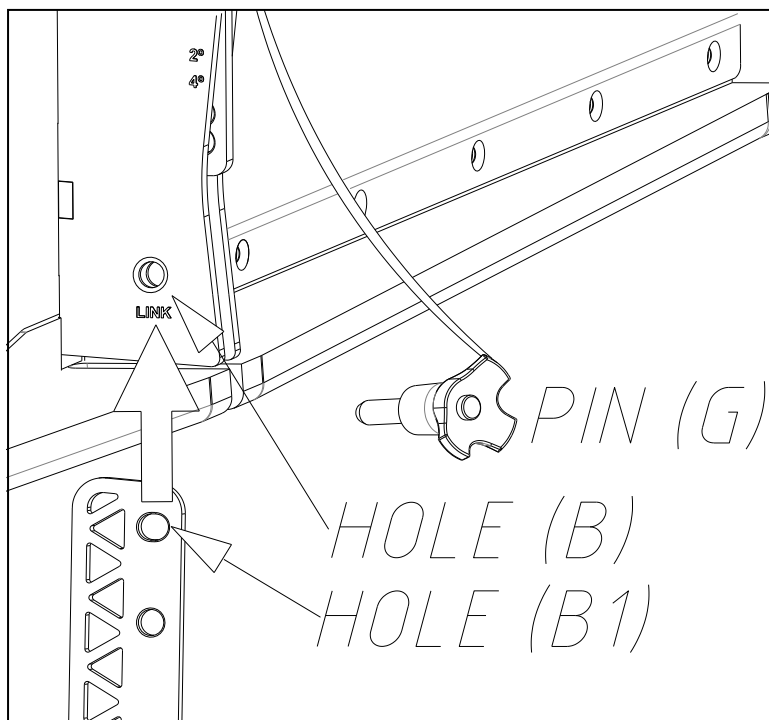


- Place the second X212AFD unit down the first X212AFD unit. Join hole (A) and (A1) on both left and right side. Put pins (E) on holes (A-A1 left and right).

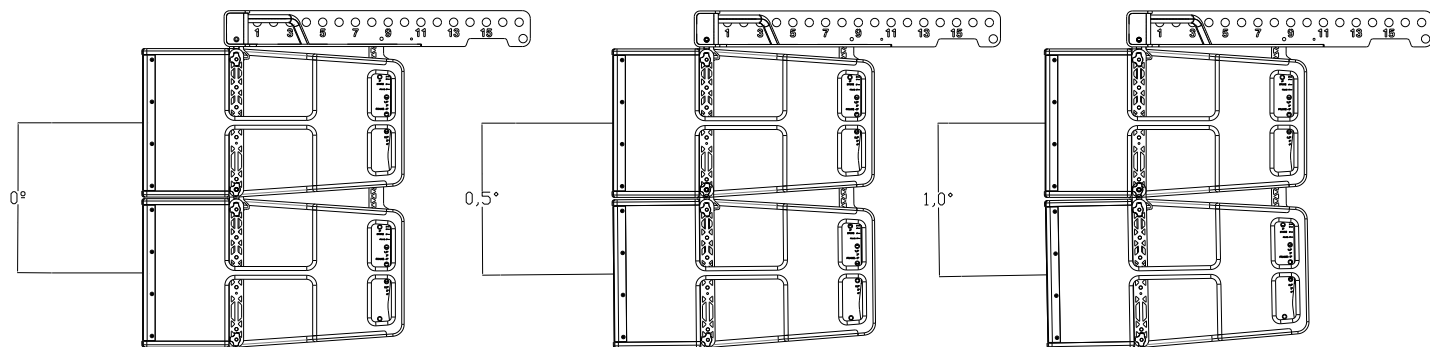


**Fig.29.** Put pins (E) on holes (A-A1)

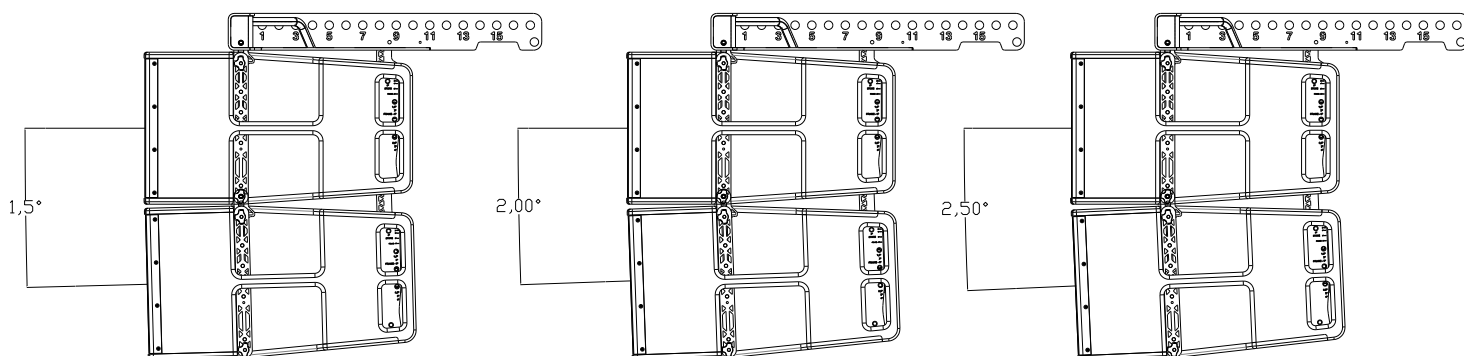
- Align hole (B) and (B1). Insert pin (G) in hole (B-B1).



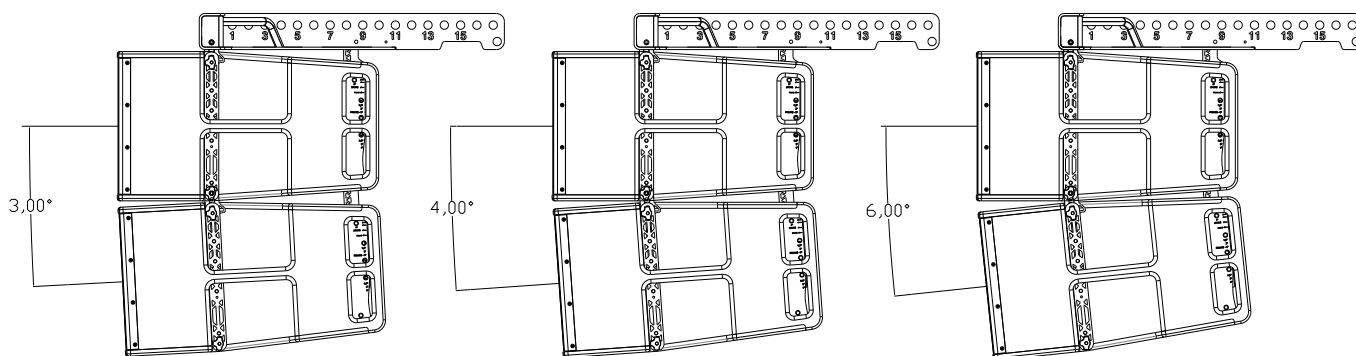
**Fig.30.** Put pin (G) on hole (B-B1)



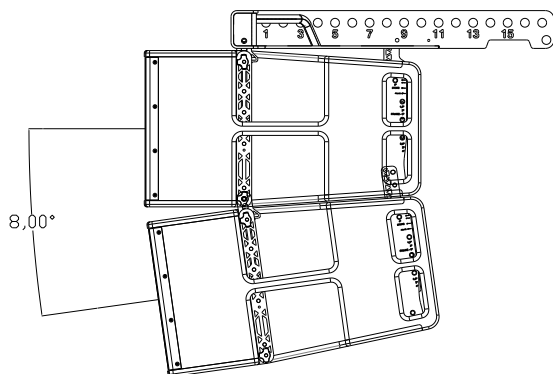
**Fig.31.** 0°, 0.5°, 1° between two X212AFD cabinets



**Fig.32.** 1.5°, 2°, 2.5° between two X212AFD cabinets



**Fig.33.** 3°, 4°, 6° between two X212AFD cabinets



**Fig.34.** 8° between two X212AFD cabinets

- For further units, proceed sequentially.

## 8 MOUNTING ACCESSORIES

### 8.1 Stacking frame for X218WFD (FR-X212)

The FR-X212 is an optional accessory for stacking the X212AFD with X218WFD. See “FR-X212 user’s manual” for more information.

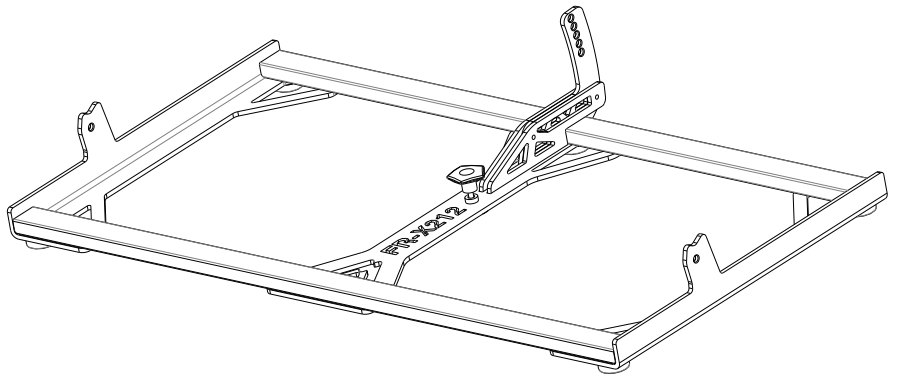
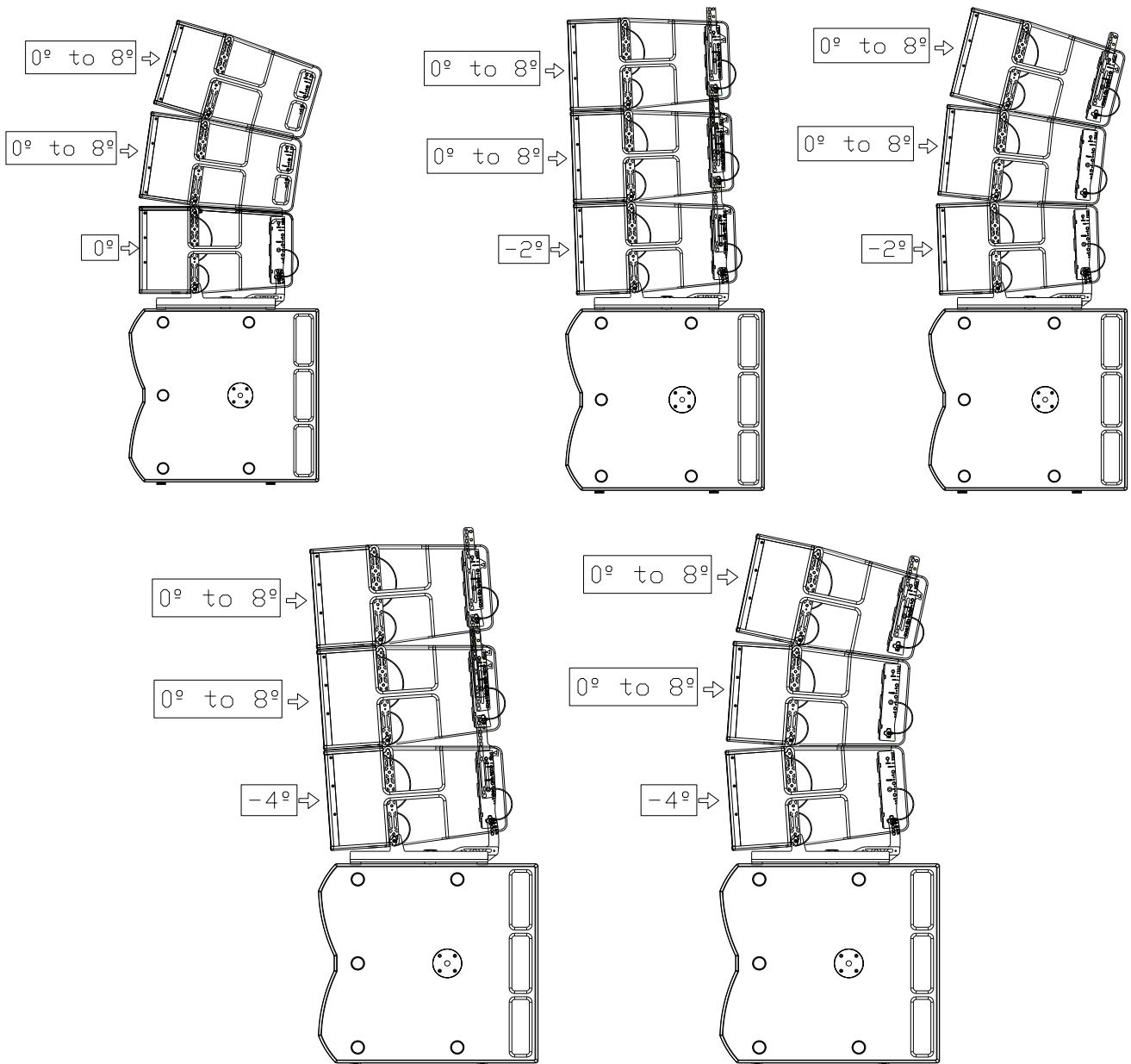
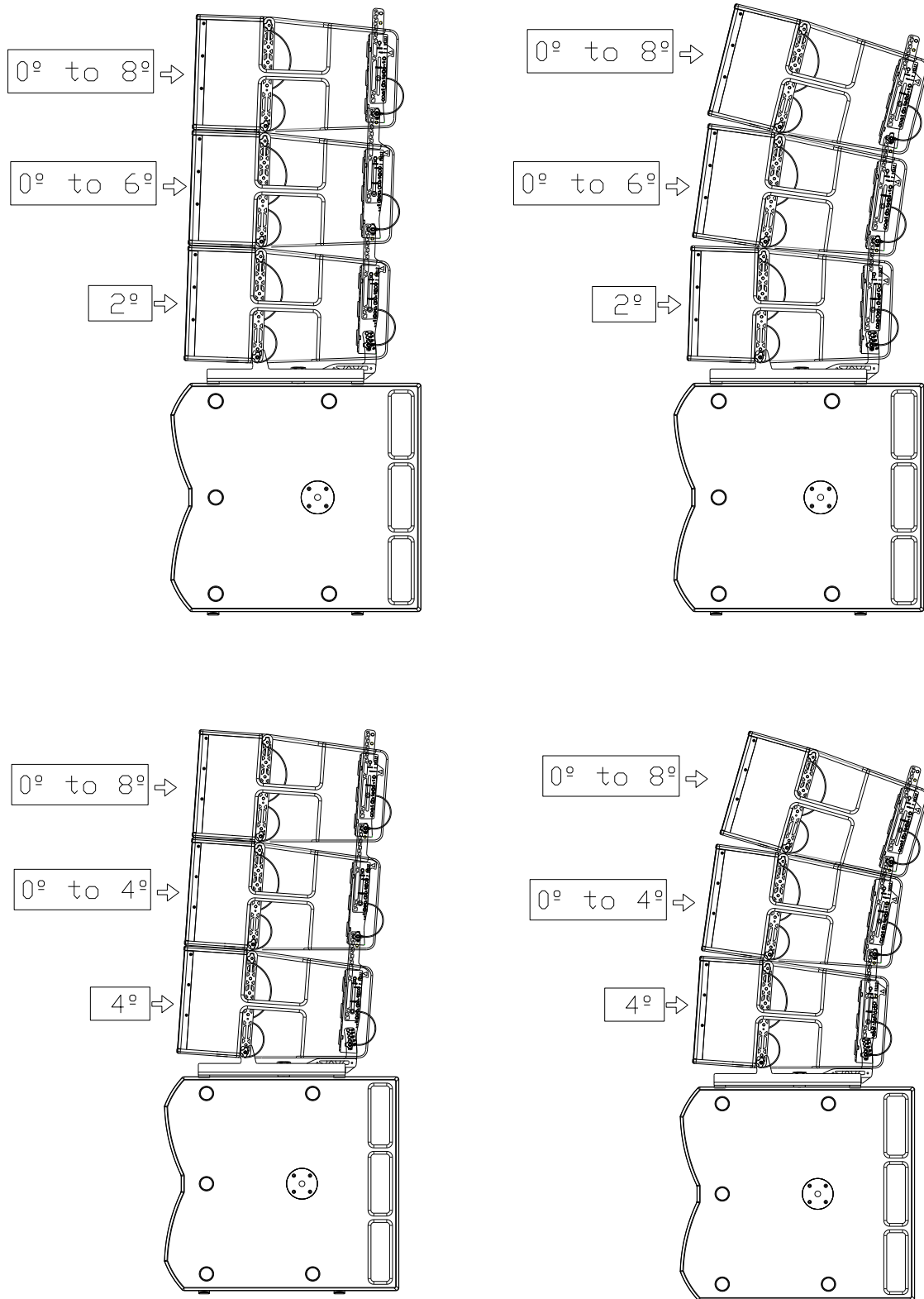


Fig.35. FR-X212 frame stacking

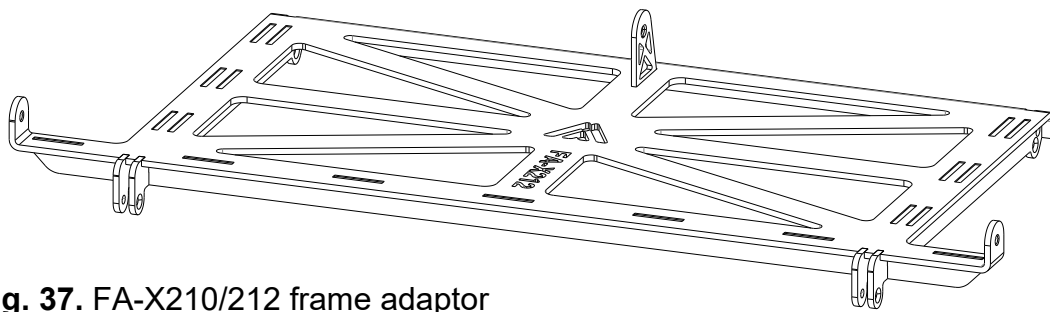




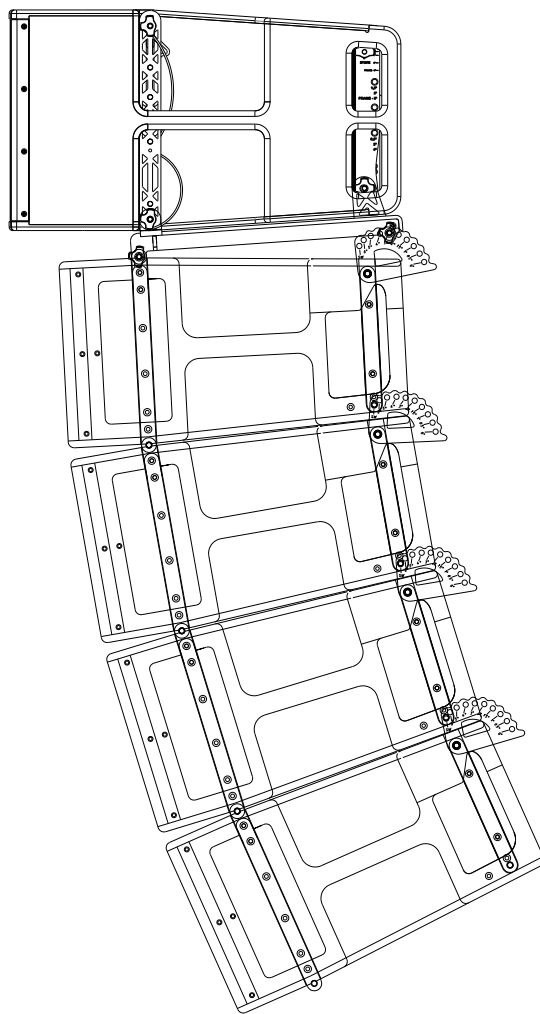
**Fig.36.** FR-X212 stacking system

## 8.2 Frame Adaptor FA-X210/212

The FA-X210/212 is an optional accessory for flying the X210 underneath the X212AFD. See “FA-X210/212 user’s manual” for more information.



**Fig. 37.** FA-X210/212 frame adaptor



**Fig. 38.** FA-X210/212 flying system

## 9 TROUBLESHOOTING

### 9.1 System not powering up

- Check the Overvoltage Protection leds
  - No LED lit: Check if voltage is arriving to the PowerCon socket, and if mains cable is in good condition. If yes, the overvoltage circuit may be damaged. Contact support.
  - Red (>250V). Voltage arriving to the PowerCon socket is above 250VAC. Check the mains voltage is in the rated limits (230VAC +/-10%). If mains voltage is OK, the overvoltage circuit may be damaged. Contact support.
  - Blue (Power On): Overvoltage circuit is functioning properly. If none of the Status LEDs or the touchscreen are being lit, the fuse in the power module may be blown. The replacement of this fuse must be carried out by specialized personnel as it is an internal component of the amplifier module.

### 9.2 No output sound

- Check with the indicators (Signal Present LED & Touchscreen) that the signal is being received by the system.
- Check that the signal cables are in good condition and connected at both ends
- The mixer output level must not be at minimum.
- Check that the mixer channel is not muted.
- Check that the system is not in MUTE or STANDBY (MUTE LED or STANDBY LED) not lit. If yes, go inside the menu using the touchscreen and deactivate them:
  - To disable the Standby go to SETUP and select STANDBY OFF.
  - To disable the MUTE go to AUDIO, GAIN and push the icon with a loudspeaker.
- Check that the system GAIN is not set to the minimum. To do that, go to the AUDIO setting using the touchscreen, select GAIN and move the slider to the 0dB position.

### 9.3 Distorted output signal

- The system is being saturated with a very high input signal, frequently caused by the same mixer. Check the output level or mixer gain channels.

### 9.4 Poor bass levels

- Check the polarity on the signal connections between the mixer and cabinets. If any of the Pins (1, 2 or 3) have been inverted at the cable ends, this will cause significant performance and sound quality loss.

### 9.5 Noise and Hum

- Check that all the connections to the active units are in good condition.
- Avoid intertwining between mains supply cables or proximity to transformers or Electromagnetic (EMI) emitting devices.
- Check there is no light intensity regulator in the same AC circuit as the unit. ALWAYS connect the sound and light circuits in different phases.
- Check that there is a proper connection to EARTH in the electrical installation.

## 9.6 Forgotten PIN for Touchscreen

- The default PIN is "1234".
- Should you have changed the PIN and forgotten it, follow these steps:
  - Turn the system off.
  - Turn the system on.
  - When the display shows the word "Initializing", press anywhere on the touch screen during at least 5 seconds.
  - The PIN will be restored to its default value "1234".

## 10 TECHNICAL FEATURES

	<b>X212AFD</b>
<b>Analog Audio Input</b>	
Sensitivity	+8dBu
Impedance	20k $\Omega$
<b>Audio Network Input</b>	
Type	Dante™ Audio Networking
Channels	1 channel @ 48kHz
<b>Mains Supply</b>	
Type	Univ. switch mode power supply
Nominal input	85-265 VAC/45-65 Hz
Average current draw	3.7A
<b>AD/DA converters</b>	24 bit / 48 kHz
<b>DSP architecture</b>	64 bit
<b>Frequency response (-10 dB)</b>	42Hz-18kHz
<b>Maximum output level (1m/continuous)</b>	141 dB
<b>Amplifier (program)</b>	2000+1000+1000W
<b>Nominal directivity (-6dB)</b>	100° x 8°
<b>Components</b>	
LF	2 x 12" neodymium woofers (3" voice coil)
MF	4 x 6" neodymium woofers (1,5" voice coil)
HF	2 x 3" titanium diaphragm drivers
<b>Cabinet</b>	
Type	Bass-reflex
Height	372 mm
Width	1100 mm
Depth	657 mm
Weight (net)	64,6 Kg
Connectors	2 x AC PowerCon (input, link) 2 x XLR (input, link)
Material	2x Ethercon RJ45 for Ethernet (connection/link) Multilayer birch plywood, steel front grilles with acoustic grey cloth
Finish	Hi-resistance black Polyurea coating



## A ANNEX. TOUCH PANEL OPERATION

Amate Audio's X212AFD internal DSP parameters could be tuned using its integrated LCD touchscreen.

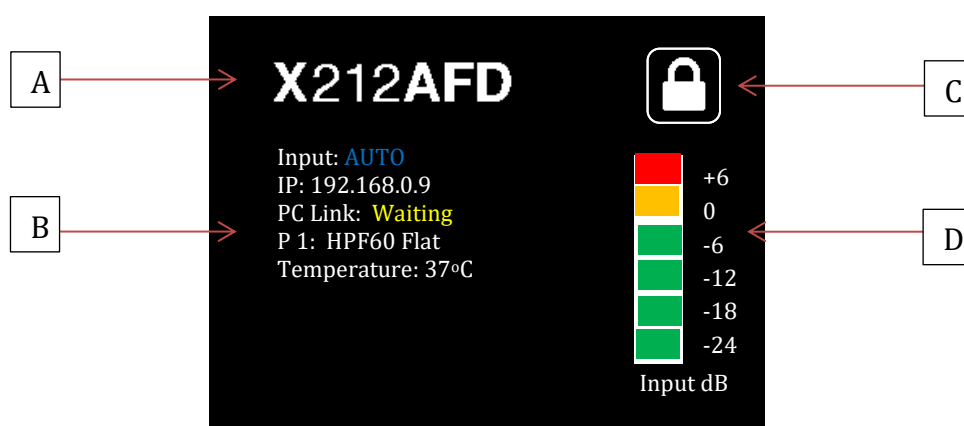
The explanations here are valid for firmware version 2.0.0 and newer.



### A.1 Main screen

Just after turning on the loudspeaker unit, a first screen shows the: Amate Audio's logo, firmware version and the processing version. Once the system is initialized, a welcome screen shows a picture of the system and the serial number.

When all the start-up process finish, the main screen is shown like:



A. Loudspeaker model

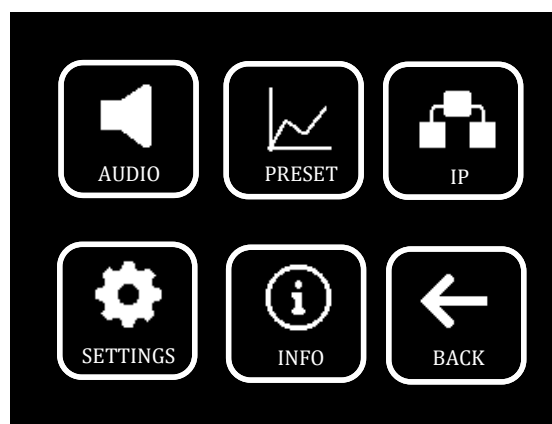
B. System status

- INPUT: Shows the selected audio source. The options are: **ANALOG** for XLR analogue input, **DANTE** for the RJ45 Dante digital audio input or **AUTO** for an automatic selection of the audio source. In presence of Dante VoIP audio a message *Flow OK* is shown
- IP: IP address of the Ethernet module
- PC Link: Connection status with DSP Studio. There's three states: **Initializing** when IP is configuring, **Waiting** for no connection established and **Link OK** when the unit achieves successful connection with DSPStudio

- P X/M X: Current preset loaded into the DSP. For user's memories the name starts with M\_
  - Temperature: Internal amplifier temperature
- C. PIN lock indicator: If a PIN lock was entered in settings, the lock icon is shown closed. In this case the unit will claim for a valid PIN. For unlocking the unit, push on the lock. When the unit is unlocked, the lock will be open.
- D. Signal indicators: Shows the input signal level in decibels (dB).

## A.2 Settings screen

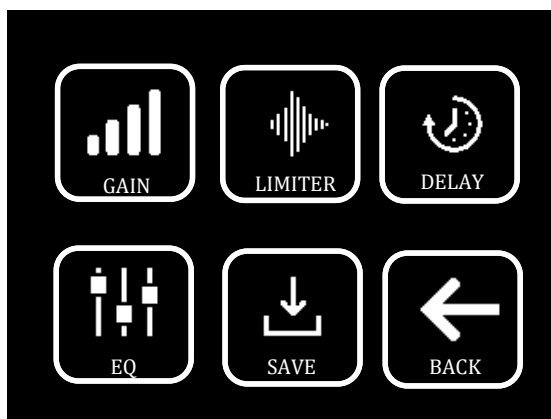
For accessing to the settings menu, just push anywhere in main screen.



Each sub-menu contains the following settings:

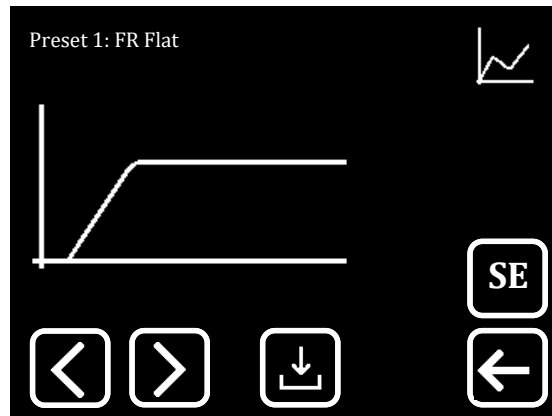
- AUDIO: General audio parameters set-up
- PRESET: Preset selection. It's possible to save user's presets.
- IP: Configuration of the Ethernet's module in order to enable communications with our control software DSP Studio.
- SETTINGS: Other unit's parameters configuration
- INFO: Detailed system information and system status
- BACK: Go back to main screen

### A.3 AUDIO sub-menu



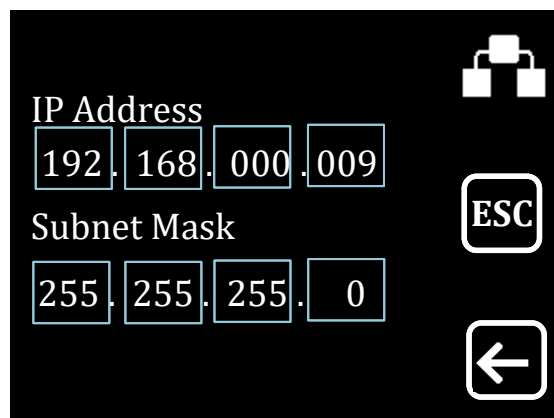
- **GAIN:** Gain reduction setup. It could be configured using a *fader* with a resolution of half a dB. Moreover, a mute button is available. An X in front of the speaker icon is shown when the unit is muted.
- **LIMITER:** Limiter threshold configuration. A Gain Reduction level indicator is available for proper threshold check.
- **DELAY:** Adjustment of the time shift among input and desired output. There's two ways of setting it: In meters or in milliseconds. Simply we've to push in the corresponding box. The space-time conversion is automatically computed. In addition, a polarity control button is available: + for positive polarity, - for negative polarity.
- **EQ:** This sub-menu helps to check the status of current filters in the DSP. These filters are applied on the top of the chosen base preset. An Ethernet communication with DSP Studio is mandatory in order to enable each filter. For the enabled filters a bypass button is available for controlling each one directly from the loudspeaker unit.
- **SAVE:** Access to DSP internal memory. Here we can save all the audio configuration in one of the free internal memory space the unit has. Push on the *Memory* box for choosing one available. Push on *Memory name* for naming it. After the previous steps, push on Save button for writing on the DSP the memory
- **BACK:** Go back to settings screen

## A.4 PRESET sub-menu



The loudspeaker unit contains several sound presets we can check inside this submenu. The browsing arrows allow us to change between presets. Press *SEL* button for loading the preset in the DSP. There is a shortcut for internal memory, so we can save a preset straight from this sub-menu.

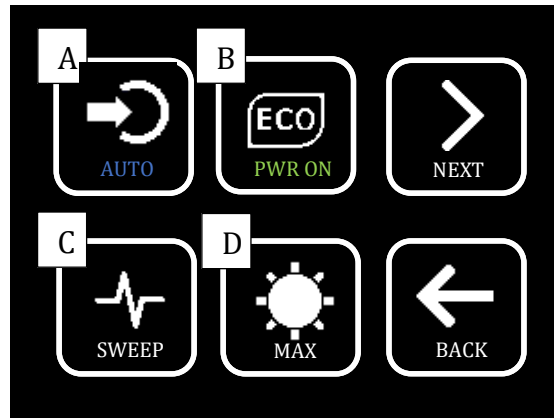
## A.5 IP submenu



In this screen we can configure the internal Ethernet module. This loudspeaker unit doesn't have *Dynamic Host Configuration Protocol*, so is necessary to set up a fixed IP address. We recommend using the same values shown in the top image for the loudspeaker unit. In the control PC/laptop we recommend using with the same subnet mask and IP 192.168.0.1

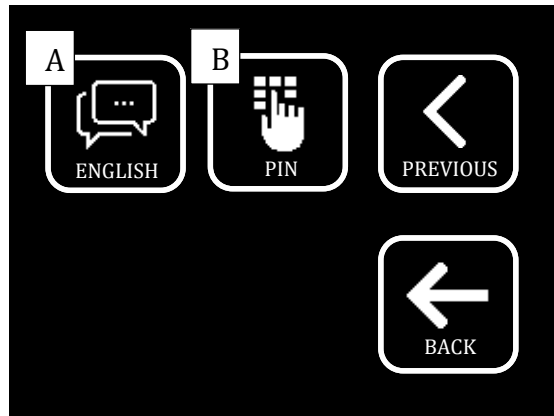
## A.6 SETTINGS submenu

Settings submenu has two screens. We can switch one to another using the NEXT/BACK buttons.



- A. INPUT selection: Here we can choose which signal input the internal processor will use. The options are: ANALOG, DANTE or AUTO. In AUTO mode the unit automatically choose the signal input according to the presence of signal. If a conflict happens (Simultaneously use of analogue and digital connectors) the unit priorities digital AoIP Dante signal. In case Dante signal is no longer available, the unit will switch to use the analogue input.
- B. ECO mode: Enabling/disabling the energy saving mode. The options are:
- PWR ON: The energy saving mode is enabled
  - Standby: The energy saving mode is disabled
  - Auto: The energy saving mode will be enabled automatically after three minutes without input signal
- C. SWEEP: Diagnosis mode. The loudspeaker will emit a frequency sweep.
- D. Backlight: Three backlight intensities: MAX (Maximum), MED (Medium), MIN (Minimum)

**On the next page:**



- A. Language: Select the interface language. The options are: ESPAÑOL, CATALA and ENGLISH.
- B. PIN lock: Configure the access code for the unit when locked. When the loudspeaker unit is locked, a closed key lock icon is shown in the main menu. Push on it for unlocking the unit.

#### **A.7 INFO submenu**

Here we can find advanced information about the unit, as well as the most relevant configurations parameters.



# DECLARATION OF CONFORMITY

In accordance with EN 45014:1998

Manufacturer's Name: "AMATE AUDIO S.L."  
Manufacturer's Address: C/ Perpinyà 25, Polígon Industrial Nord  
08226 Terrassa, (Barcelona), SPAIN  
Brand: "AMATE AUDIO"

We declare under our own responsibility that:

Product: Active speaker systems with DSP. Audio apparatus for professional use  
Name: Xcellence X212AFD

Conforms to the following product specifications:

Safety: IEC 60065-01 + A1  
EMC: EN 55022:2006  
EN 55103-1:2009  
EN 55103-2 2009  
FCC Part 15

**WARNING:**

In accordance to EN55022, this is a class A product. In a domestic environment this product may cause radio interference in which case the user may be required to take adequate measures.

**Supplementary Information**

The product herewith complies with the requirements of the:

Low Voltage Directive 2006/95/EC  
EMC Directive 2004/108/EC  
RoHS Directive 2002/95/EC  
WEEE Directive 2002/96/EC

With regard to Directive 2005/32/EC and EC Regulation 1275/2008 of 17 December 2008, this product is designed, produced, and classified as Professional Audio Equipment and thus is exempt from this Directive.

Date of issue: July 3th., 2021

Signature:

**AMATE AUDIO S.L.**  
N.I.F: B59103481  
Violinista Vellsolà, 18  
Tel: +34 93 736 23 90  
08222 - Terrassa  
Barcelona - SPAIN

**Joan A. Amate**  
General Manager

Amate Audio S.L.



Conformity Marking

EXPORT & CUSTOMER SERVICE  
Perpinyà, 25 · Polígon Industrial Nord  
08226 Terrassa · Barcelona – SPAIN  
T. +34 93 735 65 65  
export@amateaudio.com

R&D, FACTORY AND MANAGEMENT  
Violinista Vellsolà, 18  
08222 Terrassa · Barcelona – SPAIN  
T. +34 93 736 23 90  
info@amateaudio.com



*Great sound  
from Barcelona  
since 1972*

---

**XCELLENCE** speaker systems have been designed, engineered  
and manufactured in Barcelona – SPAIN by

Los **sistemas acústicos XCELLENCE** han sido diseñados y  
fabricados en Barcelona – ESPAÑA por

---

**Amate Audio S.L.**

Perpinyà, 25 · Polígon Industrial Nord · 08226 Terrassa  
T. +34 93 735 65 65 – info@amateaudio.com

R&D and FACTORY:  
Violinista Vellsolà, 18 · 08222 Terrassa

**Barcelona – SPAIN**

---

[www.amateaudio.com](http://www.amateaudio.com)